

Rolling Bearing Lubrication

FAG

Rolling Bearings

FAG OEM und Handel AG

Publ. No. WL 81 115/4 EA



Rolling Bearing Lubrication

Publ. No. WL 81 115/4 EA

FAG OEM und Handel AG

A company of the FAG Kugelfischer Group

P.O. Box 1260 · D-97 419 Schweinfurt

Phone (0 97 21) 91 2349 · Telefax (0 97 21) 91 4327

<http://www.fag.de>

Table of Contents

1	Lubricant in Rolling Bearings	3	5	Damage Due to Imperfect Lubrication	52
1.1	Functions of the Lubricant in Rolling Bearings	3	5.1	Contaminants in the Lubricant	52
1.1.1	The Different Lubricating Conditions in Rolling Bearings	3	5.1.1	Solid Foreign Particles	54
1.1.2	Lubricating Film with Oil Lubrication	4	5.1.2	How to Reduce the Concentration of Foreign Particles	54
1.1.3	Influence of the Lubricating Film and Cleanliness on the Attainable Bearing Life	6	5.1.3	Oil Filters	54
1.1.4	Lubricating Film with Grease Lubrication	12	5.1.4	Liquid Contaminants	55
1.1.5	Lubricant Layers with Dry Lubrication	13	5.2	Cleaning Contaminated Rolling Bearings	55
1.2	Calculation of the Frictional Moment	14	5.3	Prevention and Diagnosis of Incipient Bearing Damage by Monitoring	56
1.3	Operating Temperature	18			
2	Lubrication System	19	6	Glossary of Terms	57
2.1	Grease Lubrication	19			
2.2	Oil Lubrication	19			
2.3	Dry Lubrication	19			
2.4	Selection of Lubrication System	19			
2.5	Examples of the Different Lubrication Systems	21			
2.5.1	Central Lubricating System	21			
2.5.2	Oil Circulation System	22			
2.5.3	Oil Mist Lubrication System	22			
2.5.4	Oil-Air Lubrication System	22			
2.5.5	Oil and Grease Spray Lubrication	22			
3.	Lubricant Selection	24			
3.1	Selection of Suitable Greases	27			
3.1.1	Grease Stressing by Load and Speed	27			
3.1.2	Running Properties	28			
3.1.3	Special Operating Conditions and Environmental Influences	28			
3.2	Selection of Suitable Oils	30			
3.2.1	Recommended Oil Viscosity	30			
3.2.2	Oil Selection According to Operating Conditions	31			
3.2.3	Oil Selection According to Oil Properties	31			
3.3	Selection of Dry Lubricants	33			
3.4	Quickly Biodegradable Lubricants	33			
4	Lubricant Supply	34			
4.1	Grease Supply	34			
4.1.1	Lubricating Equipment	34			
4.1.2	Initial Grease Charge and Grease Renewal	34			
4.1.3	Grease Service Life	35			
4.1.4	Lubrication Intervals	35			
4.1.5	Relubrication, Relubrication Intervals	36			
4.1.6	Examples of Grease Lubrication	40			
4.2	Oil Supply	43			
4.2.1	Lubricating Equipment	43			
4.2.2	Oil Sump Lubrication	43			
4.2.3	Circulating Lubrication with Average and Above Average Oil Volumes	44			
4.2.4	Throwaway Lubrication	47			
4.2.5	Examples of Oil Lubrication	49			
4.3	Dry Lubricant Application	52			

1. Lubricant in Rolling Bearings

1.1 Functions of the Lubricant in Rolling Bearings

The lubrication of rolling bearings – similar to that of sliding bearings – mainly serves one purpose: to avoid or at least reduce metal-to-metal contact between the rolling and sliding contact surfaces, i.e. to reduce friction and wear in the bearing.

Oil, adhering to the surfaces of the parts in rolling contact, is fed between the contact areas. The oil film separates the contact surfaces preventing metal-to-metal contact (»physical lubrication«).

In addition to rolling, sliding occurs in the contact areas of the rolling bearings. The amount of sliding is, however, much less than in sliding bearings. This sliding is caused by elastic deformation of the bearing components and by the curved form of the functional surfaces.

Under pure sliding contact conditions, existing for instance between rolling elements and cage or between roller faces and lip surfaces, the contact pressure, as a rule, is far lower than under rolling contact conditions. Sliding motions in rolling bearings play only a minor role. Even under unfavourable lubrication conditions energy losses due to friction, and wear are very low. Therefore, it is possible to lubricate rolling bearings with greases of different consistency and oils of different viscosity. This means that wide speed and load ranges do not create any problems.

Sometimes, the contact surfaces are not completely separated by the lubricant film. Even in these cases, low-wear operation is possible, if the locally high temperature triggers chemical reactions between the additives in the lubricant and the surfaces of the rolling elements or rings. The resulting tribochemical reaction layers have a lubricating effect (»chemical lubrication«).

The lubricating effect is enhanced not only by such reactions of the additives but also by dry lubricants added to the oil or grease, and even by the grease thickener.

In special cases, it is possible to lubricate rolling bearings with dry or solid lubricants only.

Additional functions of rolling bearing lubricants are: protection against corrosion, heat dissipation from the bearing (oil lubrication), discharge of wear particles and contaminants from the bearing (oil circulation lubrication; the oil is filtered), enhancing the sealing effect of the bearing seals (grease collar, oil-air lubrication).

- Dry lubrication: Solid lubricants (e.g. graphite and molybdenum disulphide), applied as a thin layer on the functional surfaces, can prevent metal-to-metal contact. Such a layer can, however, be maintained over a long period only at moderate speeds and low contact pressure. Solid lubricants, added to oils or greases, also improve the lubricating efficiency in cases of metal-to-metal contact.

1.1.1 The Different Lubricating Conditions in Rolling Bearings

Friction and wear behaviour and the attainable life of a rolling bearing depend on the lubricating condition. The following lubricating conditions exist in a rolling bearing:

- Full fluid film lubrication: The surfaces of the components in relative motion are completely or nearly completely separated by a lubricant film (fig. 1a).

This is a condition of almost pure fluid friction. For continuous operation this type of lubrication, which is also referred to as fluid lubrication, should always be aimed at.

- Mixed lubrication: Where the lubricant film gets too thin, local metal-to-metal contact occurs, resulting in mixed friction (fig. 1b).
- Boundary lubrication: If the lubricant contains suitable additives, reactions between the additives and the metal surfaces are triggered at the high pressures and temperatures in the contact areas. The resulting reaction products have a lubricating effect and form a thin boundary layer (fig. 1c).

Full fluid film lubrication, mixed lubrication and boundary lubrication occur both with grease lubrication and with oil lubrication. The lubricating condition with grease lubrication depends mainly on the viscosity of the base oil. Also, the grease thickener has a lubricating effect.

1: The different lubricating conditions

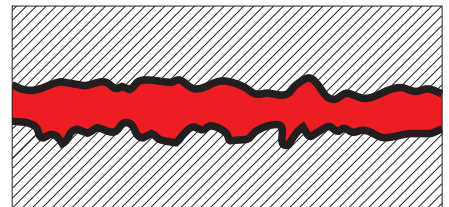

a) Full fluid film lubrication
The surfaces are completely separated by a load carrying oil film

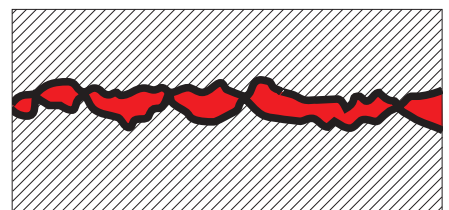

b) Mixed lubrication
Both the load carrying oil film and the boundary layer play a major role

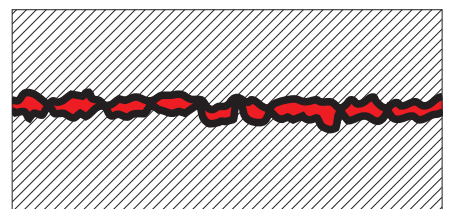

c) Boundary lubrication
The lubricating effect mainly depends on the lubricating properties of the boundary layer

■ Boundary layer ■ Lubricant layer

Lubricant in Rolling Bearings

Functions of the Lubricant in Rolling Bearings

1.1.2 Lubricating Film with Oil Lubrication

Main criterion for the analysis of the lubricating condition is the lubricating film thickness between the load transmitting rolling and sliding contact surfaces. The lubricant film between the rolling contact surfaces can be described by means of the theory of elastohydrodynamic

(EHD) lubrication. The lubrication under sliding contact conditions which exist, e.g. between the roller faces and lips of tapered roller bearings, is adequately described by the hydrodynamic lubrication theory as the contact pressure in the sliding contact areas is lower than in the rolling contact areas.

The minimum lubricant film thickness h_{\min} for EHD lubrication is calculated

using the equations for point contact and line contact shown in fig. 2. The equation for point contact takes into account the fact that the oil escapes from the gap on the sides. The equation shows the great influence of the rolling velocity v , the dynamic viscosity η_0 and the pressure-viscosity coefficient α on h_{\min} . The load Q has little influence because the viscosity rises with increasing loads and

2: Elastohydrodynamic lubricant film. Lubricant film thicknesses for point contact and line contact

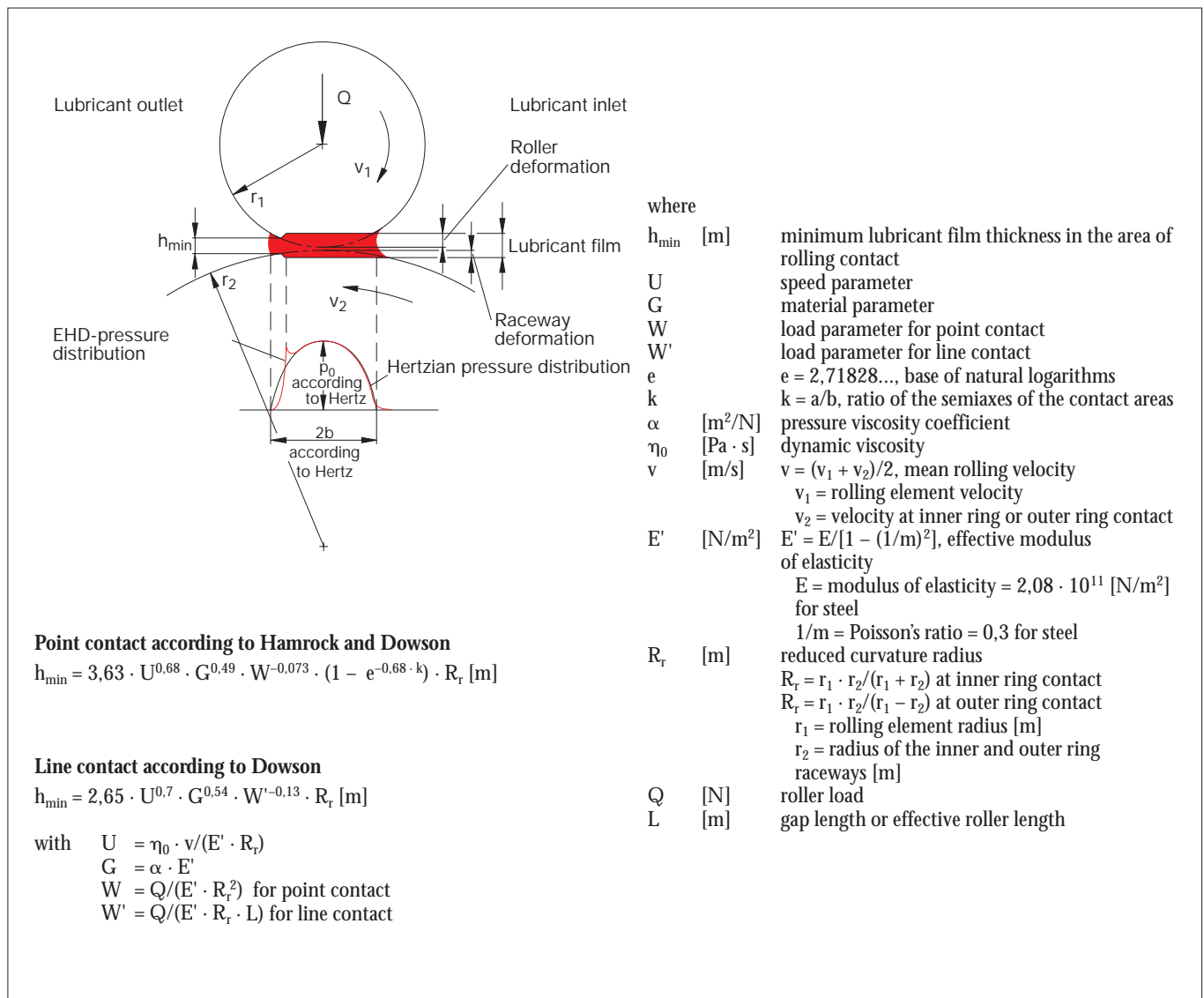

the contact surfaces are enlarged due to elastic deformation.

The calculation results can be used to check whether a sufficiently strong lubricant film is formed under the given conditions. Generally, the minimum thickness of the lubricant film should be one tenth of a micron to several tenths of a micron. Under favourable conditions the film is several microns thick.

The viscosity of the lubricating oil changes with the pressure in the rolling contact area:

$$\eta = \eta_0 \cdot e^{\alpha p}$$

η dynamic viscosity at pressure p [Pa s]

η_0 dynamic viscosity at normal pressure [Pa s]

e (= 2,71828) base of natural logarithms

α pressure-viscosity coefficient [m^2/N]

p Pressure [N/m^2]

The calculation of the lubricating condition in accordance with the EHD theory for lubricants with a mineral oil base takes into account the great influence of pressure. The pressure-viscosity behaviour of a few lubricants is shown in the diagram in fig. 3. The a_{23} diagram shown in fig. 7 (page 7) is based on the zone a-b for mineral oils. Mineral oils with EP-additives also have α values in this zone.

If the pressure-viscosity coefficient has considerable influence on the viscosity ratio, e.g. in the case of diester, fluorocar-

bon or silicone oil, the correction factors B_1 and B_2 have to be taken into account in the calculation of the viscosity ratio κ .

$$\kappa_{B1,2} = \kappa \cdot B_1 \cdot B_2$$

κ viscosity ratio for mineral oil (see section 1.1.3)

B_1 correction factor for pressure-viscosity behaviour

$$= \alpha_{\text{synthetic oil}} / \alpha_{\text{mineral oil}}$$

(α values, see fig. 3)

B_2 correction factor for varying density

$$= \rho_{\text{synthetic oil}} / \rho_{\text{mineral oil}}$$

The diagram, fig. 4, shows the curve for density ρ as a function of temperature for mineral oils. The curve for a synthetic oil can be assessed if the density ρ at 15°C is known.

3: Pressure-viscosity coefficient α as a function of kinematic viscosity ν , for pressures from 0 to 2000 bar

4: Density ρ of mineral oils as a function of temperature t

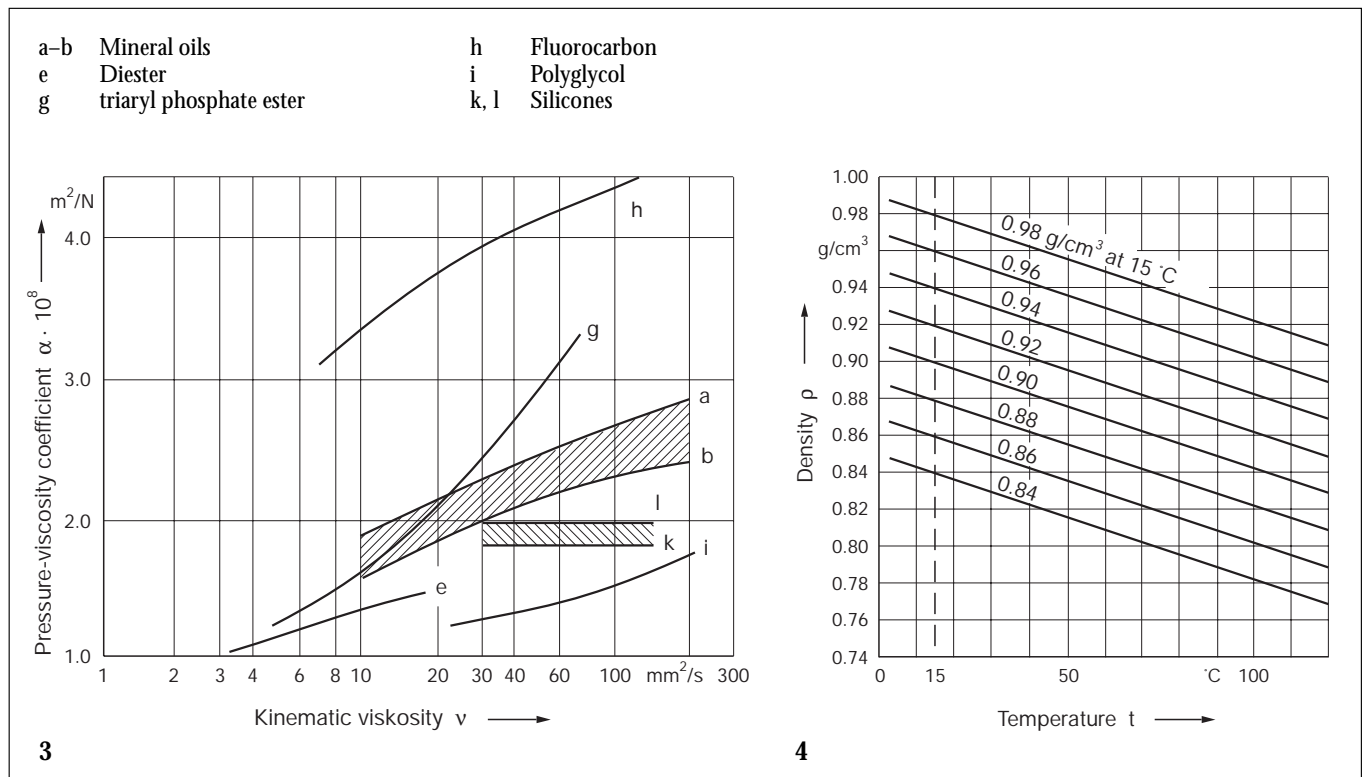

Lubricant in Rolling Bearings

Functions of the Lubricant in Rolling Bearings

1.1.3 Influence of the Lubricant Film and Cleanliness on the Attainable Bearing Life

Since the sixties, experiments and field application have made it increasingly clear that, with a separating lubricant film without contaminants in the rolling element/raceway contact areas, the service life of a moderately loaded bearing is considerably longer than that calculated by means of the classical life equation $L = (C/P)^p$. In 1981, FAG was the first bearing manufacturer to prove that rolling bearings can be fail-safe. Based on these findings, international standard recommendations and practical experience, a refined procedure for calculating the attainable life of bearings was developed.

The preconditions for endurance strength are:

- full separation of the surfaces in rolling contact by the lubricant film ($\kappa \geq 4$)
 - utmost cleanliness in the lubricating gap corresponding to $V = 0.3$
 - stress index $f_{s^*} \geq 8$.
- $f_{s^*} = C_0/P_{0^*}$
 C_0 static load rating [kN]
 see FAG catalogue
 P_{0^*} equivalent bearing load [kN]
 determined by the formula
 $P_{0^*} = X_0 \cdot F_r + Y_0 \cdot F_a$ [kN]
 where X_0 and Y_0 are factors from the FAG catalogue and
 F_r dynamic radial force
 F_a dynamic axial force

Attainable life in accordance with the FAG method:

$$L_{na} = a_1 \cdot a_{23} \cdot L \text{ [} 10^6 \text{ revolutions]}$$

or

$$L_{hna} = a_1 \cdot a_{23} \cdot L_h \text{ [h]}$$

The a_1 factor is 1 for the usual failure probability of 10%.

The a_{23} factor (product of the basic a_{23II} factor and the cleanliness factor s , see below) takes into account the effects of material and operating conditions, i.e. also that of lubrication and of the cleanliness in the lubricating gap, on the attainable life of a bearing.

The **nominal life L** (DIN ISO 281) is based on the viscosity ratio $\kappa = 1$.

The **viscosity ratio** $\kappa = \nu/\nu_1$ is used as a measure of the lubricating film development for determining the basic a_{23II} factor (diagram, fig. 7).

ν is the viscosity of the lubricating oil or of the base oil of the grease used at operating temperature (diagram, fig. 5) and ν_1 is the **rated viscosity** which depends on the bearing size (mean diameter d_m) and speed n (diagram, fig. 6).

5: Viscosity-temperature diagram for mineral oils

6. Rated viscosity ν_1 depending on bearing size and speed; D = bearing O.D., d = bore diameter

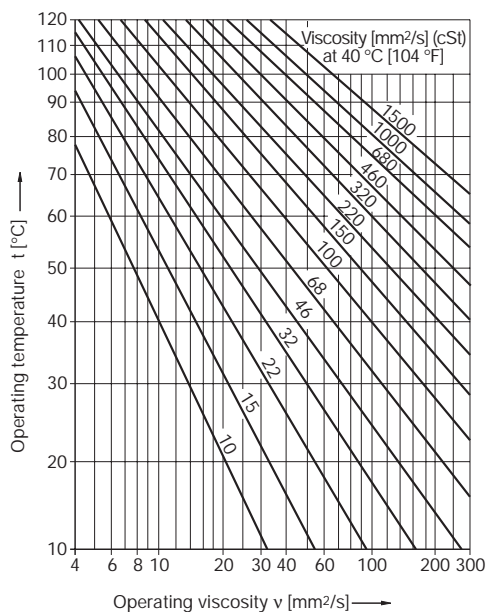

5

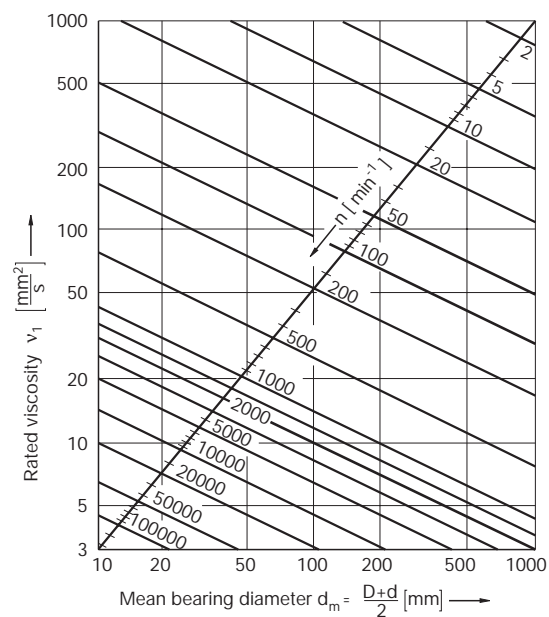

6

The equation for the attainable life L_{na} and the diagram in fig. 7 show how an operating viscosity which deviates from the rated viscosity affects the attainable bearing life. With a viscosity ratio of $\kappa = 2$ to 4 a fully separating lubricant film is formed between the contact areas. The farther κ lies below these values the larger is the mixed friction share and the more important a suitably doped lubricant.

The **operating viscosity** ν of the oil or of the base oil of the grease used, i.e. its kinematic viscosity at operating temperature, is indicated in the data sheets supplied by oil and grease manufacturers. If only the viscosity at 40°C is known the viscosity of mineral oils with an average

viscosity-temperature behaviour at operating temperature can be determined from the diagram in fig. 5.

The operating temperature for determining n depends on the frictional heat generated, cp. section 1.2. If no temperature measurements from comparable bearing locations are available the operating temperature can be assessed by means of a heat balance calculation, see section 1.3.

As the real temperature on the surface of the stressed elements in rolling contact is not known, the temperature measured on the stationary ring is assumed as the operating temperature. For bearings with favourable kinematics (ball bearings,

cylindrical roller bearings) the viscosity can be approximated based on the temperature of the stationary ring. In the case of external heating, the viscosity is determined from the mean temperatures of the bearing rings.

In heavily loaded bearings and in bearings with a high percentage of sliding (e.g. full-complement cylindrical roller bearings, spherical roller bearings and axially loaded cylindrical roller bearings) the temperature in the contact area is up to 20 K higher than the measurable operating temperature. The difference can be approached by using half the operating viscosity ν read off the V-T diagram for the formula $\kappa = \nu/\nu_1$.

7: Basic a_{23II} factor for determining the a_{23} factor

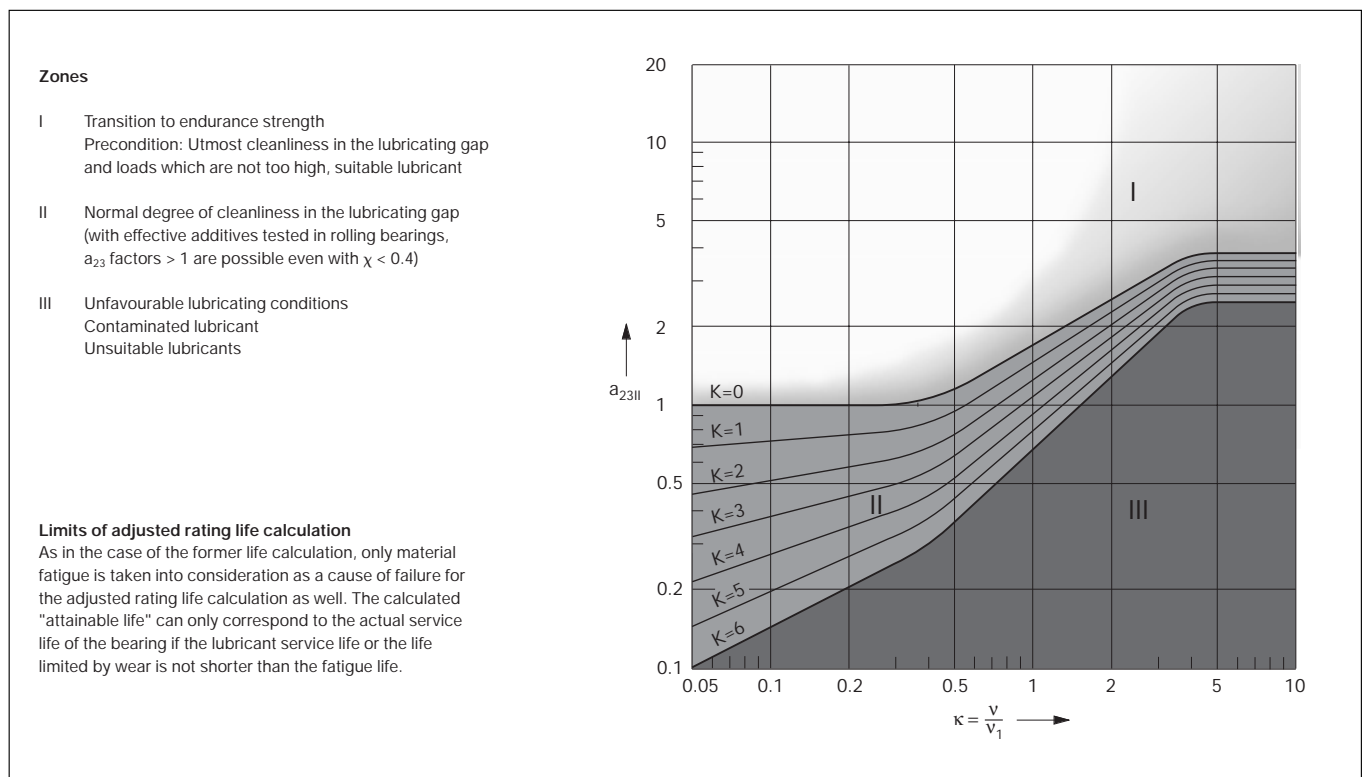

Lubricant in Rolling Bearings

Functions of the Lubricant in Rolling Bearings

The value $K = K_1 + K_2$ is required for locating the basic a_{23II} factor in the diagram shown in fig. 7.

K_1 can be read off the diagram in fig. 8 as a function of the bearing type and the stress index f_{s^*} .

K_2 depends on the viscosity ratio κ and the index f_{s^*} . The values in the diagram, fig. 9, apply to lubricants without additives or lubricants with additives

whose special effect in rolling bearings was not tested.

With $K = 0$ to 6, a_{23II} is found on one of the curves in zone II of the diagram shown in fig. 7.

With $K > 6$, a_{23II} must be expected to be in zone III. In such a case a smaller K value and thus zone II should be aimed at by improving the conditions.

About the additives:

If the surfaces are not completely separated by a lubricant film the lubricants should contain, in addition to additives which help prevent corrosion and increase ageing resistance, also suitable additives to reduce wear and increase loadability. This applies especially where $\kappa \leq 0.4$ as then wear dominates.

8: Value K_1 depending on the index f_{s^*} and the bearing type

9: Value K_2 depending on the index f_{s^*} for lubricants without additives and lubricants with additives whose effect in rolling bearings was not tested

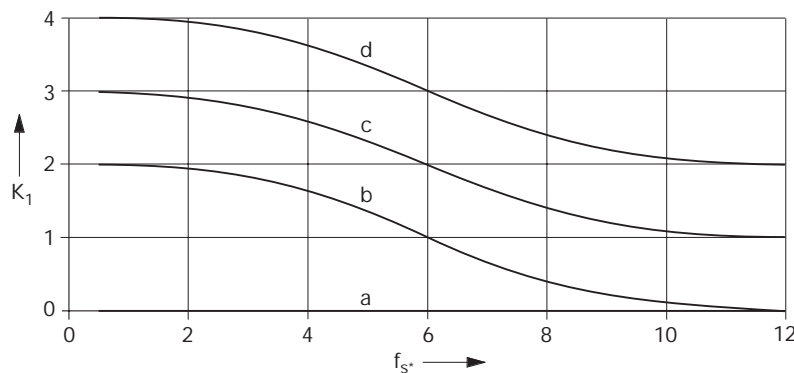

- a ball bearings
- b tapered roller bearings
cylindrical roller bearings
- c spherical roller bearings
spherical roller thrust bearings³⁾
cylindrical roller thrust bearings^{1), 3)}
- d full complement cylindrical roller bearings^{1), 2)}

- 1) Attainable only with lubricant filtering corresponding $V < 1$, otherwise $K_1 \geq 6$ must be assumed.
- 2) To be observed for the determination v : the friction is at least twice the value in caged bearings. This results in higher bearing temperature.
- 3) Minimum load must be observed.

8

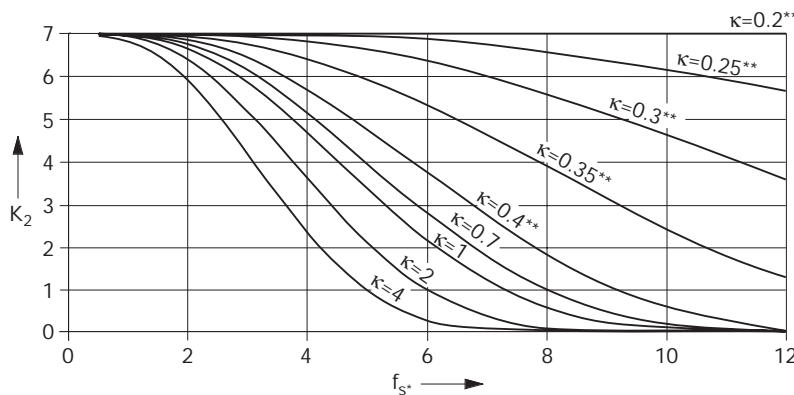

K_2 equals 0 for lubricants with additives with a corresponding suitability proof.

** With $\kappa \leq 0.4$ wear dominates unless eliminated by suitable additives.

9

The additives in the lubricants react with the metal surfaces of the bearing and form separating reaction layers which, if fully effective, can replace the missing oil film as a separating element. Generally, however, separation by a sufficiently thick oil film should be aimed at.

Cleanliness factor s

Cleanliness factor s quantifies the effect of contamination on the life. Contamination factor V is required to obtain s .

$s = 1$ always applies to "normal cleanliness" ($V = 1$), i.e. $a_{23II} = a_{23}$.

With "improved cleanliness" ($V = 0.5$) and "utmost cleanliness" ($V = 0.3$)

cleanliness factor $s \geq 1$ is obtained from the right diagram (a) in fig. 10, based on the index f_s^* and depending on the viscosity ratio κ .

$s = 1$ applies to $\kappa \leq 0.4$.

With $V = 2$ (moderately contaminated lubricant) and $V = 3$ (heavily contaminated lubricant), s is obtained from zone b of the diagram, fig. 10.

10: Diagram for determining the cleanliness factor s

a Diagram for improved ($V = 0.5$) and utmost ($V = 0.3$) cleanliness

b Diagram for moderately contaminated lubricant ($V = 2$) and heavily contaminated lubricant ($V = 3$)

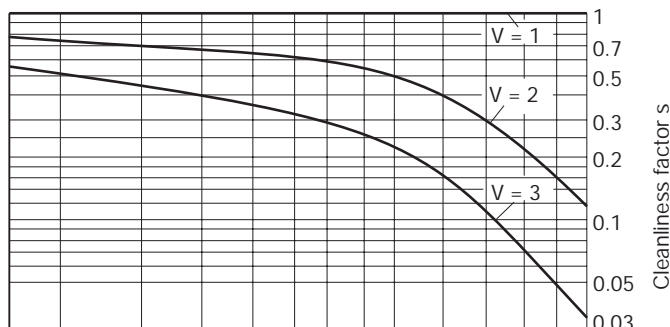
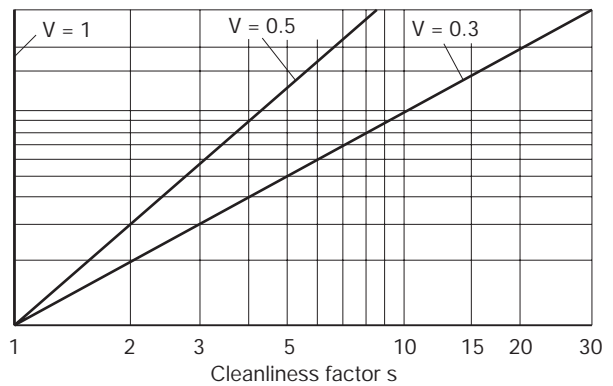
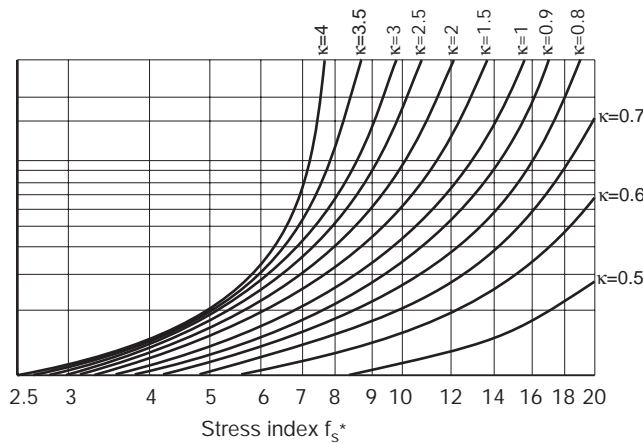

A cleanliness factor $s > 1$ is attainable for full-complement bearings only if wear in roller/roller contact is eliminated by a high-viscosity lubricant and utmost cleanliness (oil cleanliness according to ISO 4406 at least 11/7).

Lubricant in Rolling Bearings

Functions of the Lubricant in Rolling Bearings

Contamination factor V

Contamination factor V depends on the bearing cross section, the type of contact between the mating surfaces and the cleanliness level of the oil, table in fig. 11.

If hard particles from a defined size on are cycled in the most heavily stressed contact area of a rolling bearing, the resulting indentations in the contact surfaces lead to premature material fatigue. The smaller the contact area, the more damaging the effect of a particle of a defined size.

At the same contamination level small bearings react, therefore, more sensitively than larger ones and bearings with point contact (ball bearings) are more vulnerable than bearings with line contact (roller bearings).

The necessary oil cleanliness class according to ISO 4406 (fig. 12) is an objectively measurable level of the contamination of a lubricant. It is determined by the standardized particle-counting method.

The numbers of all particles $> 5 \mu\text{m}$ and all particles $> 15 \mu\text{m}$ are allocated to a certain oil cleanliness class. An oil cleanliness 15/12 according to ISO 4406 means that between 16000 and 32000 particles $> 5 \mu\text{m}$ and between 2000 and 4000 particles $> 15 \mu\text{m}$ are present per 100 ml of a fluid. The step from one class to the next is by doubling or halving the particle number.

Specially particles with a hardness of $> 50 \text{ HRC}$ reduce the life of rolling bearings. These are particles of hardened steel, sand and abrasive particles. Abrasive particles are particularly harmful.

If the major part of foreign particles in the oil samples is in the life-reducing hardness range, which is the case in many technical applications, the cleanliness class determined with a particle counter can be compared directly with the valves of the table on page 46. If, however, the filtered out contaminants are found, after counting, to be almost exclusively mineral matter as, for example, the particularly

harmful moulding sand or abrasive grains, the measured values must be increased by one to two cleanliness classes before determining the contamination factor V. On the other hand, if the greater part of the particles found in the lubricant are soft materials such as wood, fibres or paint, the measured value of the particle counter should be reduced correspondingly.

A defined filtration ratio β_x should exist in order to reach the oil cleanliness required (cp. Section 5.1.3). A filter of a certain filtration ratio, however, is not automatically indicative of an oil cleanliness class.

Cleanliness scale

Normal cleanliness ($V = 1$) is assumed for frequently occurring conditions:

- Good sealing adapted to the environment
- Cleanliness during mounting
- Oil cleanliness according to $V = 1$
- Observing the recommended oil change intervals

Utmost cleanliness ($V = 0.3$): cleanliness, in practice, is utmost in

- bearings which are greased and protected by seals or shields against dust by FAG. The life of fail-safe types is usually limited by the service life of the lubricant.
- bearings greased by the user who observes that the cleanliness level of the newly supplied bearing will be maintained throughout the entire operating time by fitting the bearing under top cleanliness conditions into a clean housing, lubricates it with clean grease and takes care that dirt cannot enter the bearing during operation (for suitable FAG Arcanol rolling bearing greases see page 57).

- bearings with circulating oil system if the circulating system is flushed prior to the first operation of the cleanly fitted bearings (fresh oil to be filled in via superfine filters) and oil cleanliness classes according to $V = 0.3$ are ensured during the entire operating time.

Heavily contaminated lubricant ($V = 3$) should be avoided by improving the operating conditions. Possible causes of heavy contamination:

- The cast housing was inadequately or not at all cleaned (foundry sand, particles from machining left in the housing).
- Abraded particles from components which are subject to wear enter the circulating oil system of the machine.
- Foreign matter penetrates into the bearing due to an unsatisfactory seal.
- Water which entered the bearing, also condensation water, caused standstill corrosion or deterioration of the lubricant properties.

The intermediate values $V = 0.5$ (improved cleanliness) and $V = 2$ (moderately contaminated lubricant) must only be used where the user has the necessary experience to judge the cleanliness conditions accurately.

Worn particles also cause wear. FAG selected the heat treatment of the bearing parts in such a way that, in the case of $V = 0.3$, bearings with low sliding motion percentage (e.g. radial ball bearings and radial cylindrical roller bearings) show hardly any wear even after very long periods of time.

Cylindrical roller thrust bearings, full-complement cylindrical roller bearings and other bearings with high sliding motion shares react strongly to small hard contaminants. In such cases, superfine filtration of the lubricant can prevent critical wear.

11: Guide values for the contamination factor V

(D-d)/2 mm	V	Point contact required oil cleanliness class according to ISO 4406 ¹⁾	guide values for filtration ratio according to ISO 4572	Line contact required oil cleanliness class according to ISO 4406 ¹⁾	guide values for filtration ratio according to ISO 4572
≤ 12.5	0.3	11/8	$\beta_3 \geq 200$	12/9	$\beta_3 \geq 200$
	0.5	12/9	$\beta_3 \geq 200$	13/10	$\beta_3 \geq 75$
	1	14/11	$\beta_6 \geq 75$	15/12	$\beta_6 \geq 75$
	2	15/12	$\beta_6 \geq 75$	16/13	$\beta_{12} \geq 75$
	3	16/13	$\beta_{12} \geq 75$	17/14	$\beta_{25} \geq 75$
> 12.5 ... 20	0.3	12/9	$\beta_3 \geq 200$	13/10	$\beta_3 \geq 75$
	0.5	13/10	$\beta_3 \geq 75$	14/11	$\beta_6 \geq 75$
	1	15/12	$\beta_6 \geq 75$	16/13	$\beta_{12} \geq 75$
	2	16/13	$\beta_{12} \geq 75$	17/14	$\beta_{25} \geq 75$
	3	18/14	$\beta_{25} \geq 75$	19/15	$\beta_{25} \geq 75$
> 20 ... 35	0.3	13/10	$\beta_3 \geq 75$	14/11	$\beta_6 \geq 75$
	0.5	14/11	$\beta_6 \geq 75$	15/12	$\beta_6 \geq 75$
	1	16/13	$\beta_{12} \geq 75$	17/14	$\beta_{12} \geq 75$
	2	17/14	$\beta_{25} \geq 75$	18/15	$\beta_{25} \geq 75$
	3	19/15	$\beta_{25} \geq 75$	20/16	$\beta_{25} \geq 75$
> 35	0.3	14/11	$\beta_6 \geq 75$	14/11	$\beta_6 \geq 75$
	0.5	15/12	$\beta_6 \geq 75$	15/12	$\beta_{12} \geq 75$
	1	17/14	$\beta_{12} \geq 75$	18/14	$\beta_{25} \geq 75$
	2	18/15	$\beta_{25} \geq 75$	19/16	$\beta_{25} \geq 75$
	3	20/16	$\beta_{25} \geq 75$	21/17	$\beta_{25} \geq 75$

The oil cleanliness class can be determined by means of oil samples by filter manufacturers and institutes. It is a measure of the probability of life-reducing particles being cycled in a bearing. Suitable sampling should be observed (see e.g. DIN 51 750). Today, on-line measuring instruments are available. The cleanliness classes are reached if the entire oil volume flows through the filter within a few minutes. To ensure a high degree of cleanliness flushing is required **prior to bearing operation**.

For example, filtration ratio $\beta_3 \geq 200$ (ISO 4572) means that in the so-called multi-pass test only one of 200 particles $\geq 3 \mu\text{m}$ passes through the filter. Filters with coarser filtration ratios than $\beta_{25} \geq 75$ should not be used due to the ill effect on the other components within the circulation system.

¹⁾ Only particles with a hardness > 50 HRC have to be taken into account.

12: Oil cleanliness classes according to ISO 4406 (excerpt)

Number of particles per 100 ml		Code		
over 5 μm		over 15 μm		
more than	up to	more than	up to	
500000	1000000	64000	130000	20/17
250000	500000	32000	64000	19/16
130000	250000	16000	32000	18/15
64000	130000	8000	16000	17/14
32000	64000	4000	8000	16/13
16000	32000	2000	4000	15/12
8000	16000	1000	2000	14/11
4000	8000	500	1000	13/10
2000	4000	250	500	12/9
1000	2000	130	250	11/8
1000	2000	64	130	11/7
500	1000	32	64	10/6
250	500	32	64	9/6

Lubricant in Rolling Bearings

Functions of the Lubricant in Rolling Bearings

1.1.4 Lubricating Film with Grease Lubrication

With lubricating greases, bearing lubrication is mainly effected by the base oil, small quantities of which are separated by the thickener over time. The principles of the EHD theory also apply to grease lubrication. For calculating the viscosity ratio ν/ν_1 the operating viscosity of the base oil is applied. Especially with low α values the thickener and the additives increase the lubricating effect.

If a grease is known to be appropriate for the application in hand – e.g. the FAG Arcanol rolling bearing greases (see page 57) – and if good cleanliness and sufficient relubrication are ensured the same K_2 values can be assumed as for suitably doped oils. If such conditions are not given, a factor from the lower curve of zone II should be selected for determining the a_{23II} value, to be on the safe side. This applies especially if the specified lubrication interval is not observed. The selection of the right grease is particularly important for bearings with a high sliding motion rate and for large and heavily stressed bearings. In heavily loaded bearings the lubricating effect of the thickener and the right doping are of particular importance.

Only a very small amount of the grease participates actively in the lubricating process. Grease of the usual consistency is for the most part expelled from the bearing and settles at the bearing sides or escapes from the bearing via the seals. The grease quantity remaining on the running areas and clinging to the bearing insides and outsides continuously separates the small amount of oil required to lubricate the functional surfaces. Under moderate loads the grease quantity remaining between the rolling contact areas is sufficient for lubrication over an extended period of time.

The oil separation rate depends on the grease type, the base oil viscosity, the size of the oil separating surface, the grease temperature and the mechanical stressing of the grease.

The effect of the grease thickener becomes apparent when the film thickness is measured as a function of operating time. On start-up of the bearing a film thickness, depending on the type of thickener, develops in the contact areas which is clearly greater than that of the base oil. Grease alteration and grease displacement quickly cause the film thickness to be reduced, fig. 13.

In spite of a possibly reduced film thickness a sufficient lubricating effect is maintained throughout the lubrication

interval. The thickener and the additives in the grease decisively enhance the lubricating effect so that no life reduction has to be expected. For long lubrication intervals, the grease should separate just as much oil as needed for bearing lubrication. In this way, oil separation over a long period is ensured. Greases with a base oil of very high viscosity have a smaller oil separation rate. In this case, adequate lubrication is only possible by packing the bearing and housing with grease to capacity or short relubrication intervals.

The lubricating effect of the thickener becomes particularly evident in the operation of rolling bearings in the mixed friction range.

13: Ratio of the grease film thickness to the base oil film thickness as a function of operating time

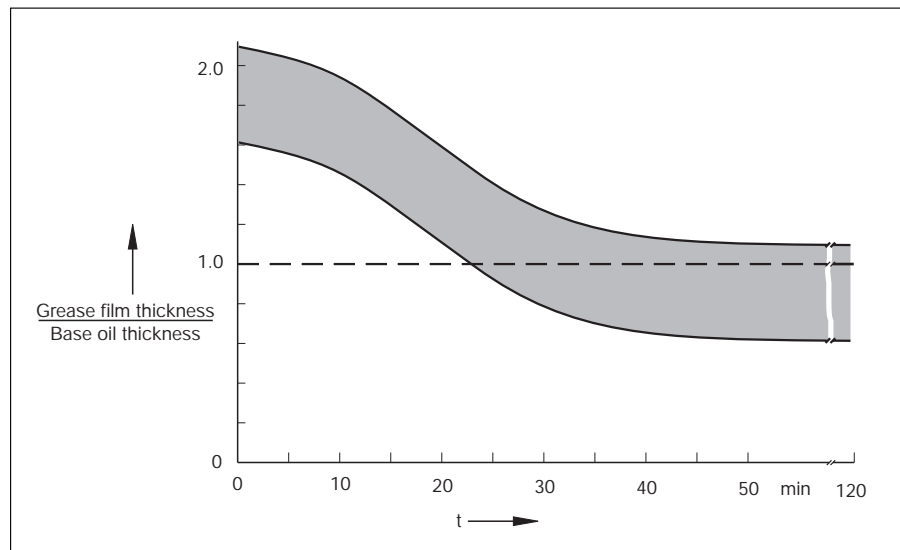

1.1.5 Lubricating Layers with Dry Lubrication

The effect of dry lubrication mainly consists of compensating for surface roughness as a result of which the effective roughness depth of the surfaces is reduced. Depending on the load and type of material, the dry lubricant is either rubbed into the metal surface or chemical reactions with the surface are released during sliding and rolling.

In dry lubricants with layer lattice structure, the lamellas of the dry lubricant slide relative to one another under pressure. Therefore, sliding occurs away from the metal surfaces, within the lubri-

cant layers (fig. 14). The compressible dry lubricant layer distributes the pressure uniformly on a larger surface. Dry lubricants without layer-lattice structure are phosphates, oxides, hydroxides and sulphides. Other dry lubricants are soft metal films. Due to their low shear strength, they have a positive frictional behaviour. Generally, lives are considerably shorter with dry lubrication than with oil or grease lubrication. The dry lubricant layer is worn off by sliding and rolling stressing.

Oil and grease reduce the service life of dry lubricant layers depending on the treatment of the surface and the type of dry lubricant used. Sliding lacquers can

soften and change their structure; this causes the friction between the surfaces to increase. Many lubricants are available with dry lubricant additives, preferably MoS₂. The most commonly used quantities are 0.5 to 3 weight percent colloidal MoS₂ in oils and 1 to 10 weight percent in greases. A greater concentration of MoS₂ is necessary for high-viscosity oils, in order to noticeably improve the lubricating efficiency. The dispersions with particles smaller than 1 micron are very stable; the dispersed particles remain in suspension.

Dry lubricants in oil or grease contribute to the lubrication only where the contact surfaces are not fully separated by the lubricant film (mixed lubrication). The load is accommodated more easily in the contact area, i.e. it is transmitted with less friction and less wear. Dry lubricant in oil can be advantageous during the run-in period when an uninterrupted lubricating oil film has not yet formed due to the surface roughness. With high-speed bearings, dry lubricant additives can have a negative effect on high-speed operation because they increase bearing friction and temperature.

14: Working mechanism of solid lubricants with layer-lattice structure, e.g. MoS₂

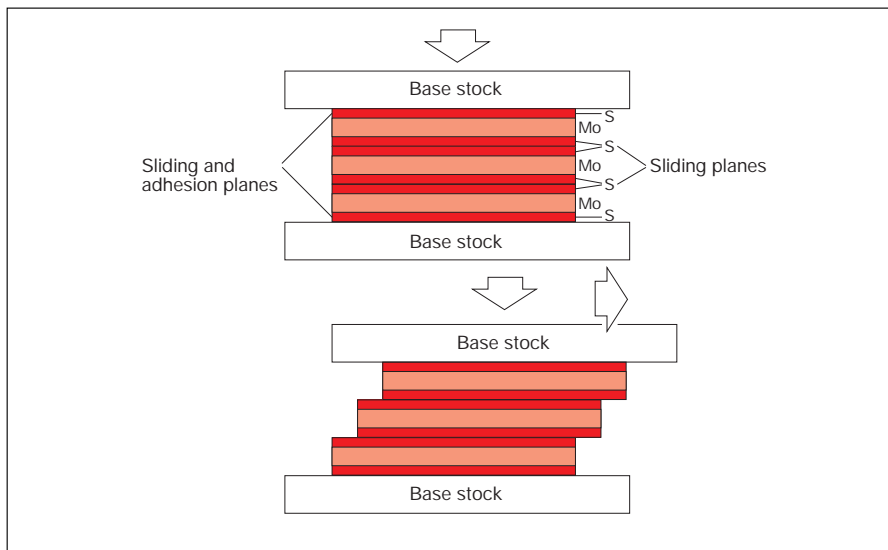

Lubricant in Rolling Bearings

Calculation of the Frictional Moment

1.2 Calculation of the Frictional Moment

The frictional moment M of a rolling bearing, i.e. the sum total of rolling friction, sliding friction and lubricant friction, is the bearing's resistance to motion. The magnitude of M depends on the loads, the speed and the lubricant viscosity (fig. 15). The frictional moment comprises a load-independent component M_0 and a load-dependent component M_1 . The black triangle to the left of the dot-dash line shows that with low speeds and high loads a considerable mixed friction share R_M can be added to M_0 and M_1 as in this area the surfaces in rolling contact are not yet separated by a lubricant film. The zone to the right of the dot-dash line shows that with a separating lubricating film which develops under normal operating conditions the entire frictional moment consists only of M_0 and M_1 .

$$M = M_0 + M_1 \quad [\text{N mm}]$$

M [N mm] total frictional moment of the bearing

M_0 [N mm] load-independent component of the frictional moment

M_1 [N mm] load-dependent component of the frictional moment

Mixed friction can occur in the raceway, at the lips and at the cage of a bearing; under unfavourable operating conditions it can be very pronounced but hard to quantify.

In deep groove ball bearings and purely radially loaded cylindrical roller bearings with a cage the mixed friction share according to fig. 15 is negligible. The frictional moment of axially loaded cylindrical roller bearings is determined by means of the equations given at the end of section 1.2.

Bearings with a **high sliding motion rate** (full-complement cylindrical roller bearings, tapered roller bearings, spherical roller bearings, thrust bearings) run, after the run-in period, outside the mixed friction range if the following condition is fulfilled:

$$n \cdot \nu / (P/C)^{0.5} \geq 9000$$

n [min⁻¹] speed

ν [mm²/s] operating viscosity of the oil or grease base oil

P [kN] equivalent dynamic load

C [kN] dynamic load rating

The **load-independent component of the frictional moment**, M_0 , depends on the operating viscosity ν of the lubricant and on the speed n . The operating viscosity, in turn, is influenced by the bearing friction through the bearing temperature. In addition, the mean bearing diameter d_m and especially the width of the rolling

contact areas – which considerably varies from type to type – have an effect on M_0 . The load-independent component M_0 of the frictional moment is determined, in accordance with the experimental results, from

$$M_0 = f_0 \cdot 10^{-7} \cdot (\nu \cdot n)^{2/3} \cdot d_m^3 \quad [\text{N mm}]$$

where

M_0 [N mm] load-independent component of the frictional moment

f_0 index for bearing type and lubrication type (table, fig. 16).

15: Frictional moment in rolling bearings as a function of speed, lubricant viscosity and loads.

In ball bearings (except thrust ball bearings) and purely radially loaded cylindrical roller bearings the mixed friction triangle (left) is negligible, i.e. $R_M \approx 0$.

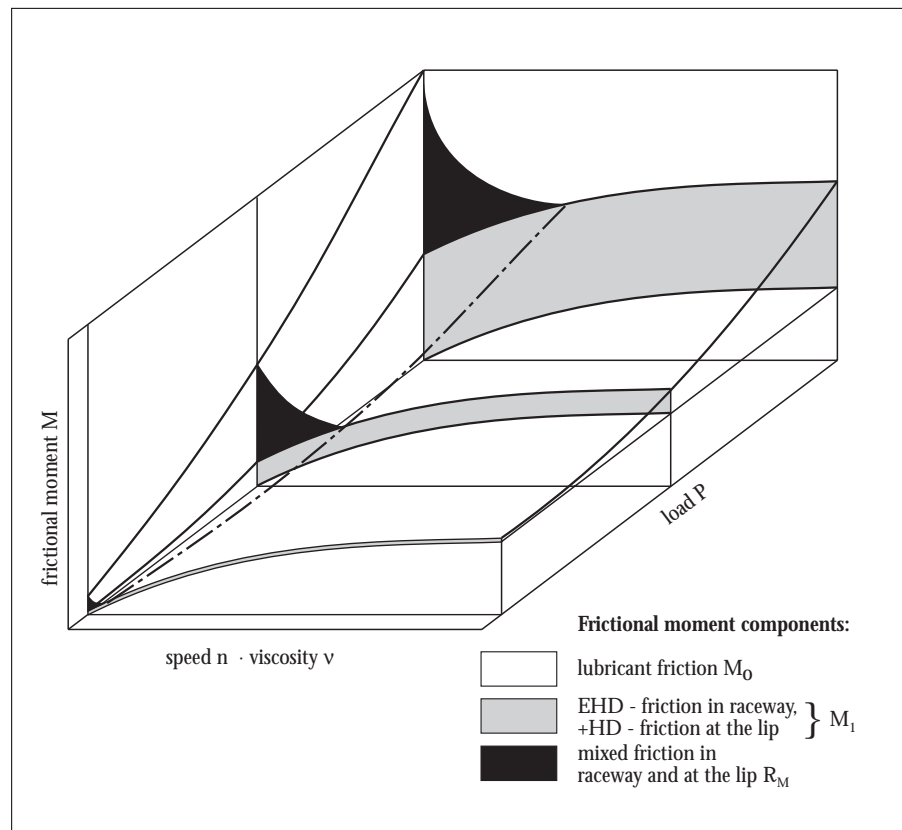

ν [mm²/s] operating viscosity of the oil or grease base oil
 fig. 5, page 6)
 n [min⁻¹] bearing speed
 d_m [mm] $(D + d)/2$ mean bearing diameter

The index f_0 is indicated in the table, fig. 16, for oil bath lubrication where the oil level in the stationary bearing reaches the centre of the bottommost rolling element. F_0 increases – for an identical d_m – with the size of the balls or with the length of the rollers, i.e. it also increases, indirectly, with the size of the bearing

cross section. Therefore, the table indicates higher f_0 values for wide bearing series than for narrow ones. If radial bearings run on a vertical shaft under radial load, twice the value given in the table (fig. 16) has to be assumed; the same applies to a large cooling-oil flow rate or an excessive amount of grease (i.e. more grease than can be displaced laterally).

The f_0 values of freshly greased bearings resemble, in the starting phase, those of bearings with oil bath lubrication. After the grease is distributed within the bearing, half the f_0 value from the table

(fig. 16) has to be assumed. Then it is as low as that obtained with oil throwaway lubrication. If the bearing is lubricated with a grease which is appropriate for the application, the frictional moment M_0 is obtained mainly from the internal frictional resistance of the base oil.

Exact M_0 values for the most diverse greases can be determined in field trials. On request FAG will conduct such tests using the friction moment measurement instrument R 27 which was developed especially for this purpose.

16: Index f_0 for the calculation of M_0 , depending on bearing type and series, for oil bath lubrication; for grease lubrication after grease distribution and with oil throwaway lubrication these values have to be reduced by 50 %.

Bearing type Series	Index f_0 for oil bath lubrication	Bearing type Series	Index f_0 for oil bath lubrication
deep groove ball bearings	1,5...2	needle roller bearings NA48, NA49	5...5,5
self-aligning ball bearings		tapered roller bearings	
12	1,5	302, 303, 313	3
13	2	329, 320, 322, 323	4,5
22	2,5	330, 331, 332	6
23	3		
angular contact ball bearings, single row		spherical roller bearings	
72	2	213, 222	3,5...4
73	3	223, 230, 239	4,5
		231, 232	5,5...6
angular contact ball bearings, double row		240, 241	6,5...7
32	3,5		
33	6	thrust ball bearings	
four point bearings	4	511, 512, 513, 514	1,5
		522, 523, 524	2
cylindrical roller bearings		cylindrical roller thrust bearings	
with cage:		811	3
2, 3, 4, 10	2	812	4
22	3		
23	4	spherical roller thrust bearings	
30	2,5	292E	2,5
full complement		293E	3
NCF29V	6	294E	3,3
NCF30V	7		
NNC49V	11		
NJ23VH	12		
NNF50V	13		

Lubricant in Rolling Bearings

Calculation of the Frictional Moment

The load-dependent frictional moment component, M_1 , results from the rolling friction and the sliding friction at the lips and guiding areas of the cage. The calculation of M_1 (see following equation) using the index f_1 (table, fig. 17) requires a separating lubricating film in the rolling contact areas ($\lambda = \nu/\nu_1 \geq 1$). Under these conditions, M_1 barely varies with speed, but it does vary with the size of the contact areas and consequently with the rolling element/raceway curvature ratio and the loading of the bearing. Additional parameters are bearing type and size.

The load-dependent frictional moment M_1 is calculated as follows:

$$M_1 = f_1 \cdot P_1 \cdot d_m \text{ [N mm]}$$

where

M_1 [N mm]	load-dependent component of the frictional moment
f_1	index taking into account the amount of load, see table (fig. 17)
P_1 [N]	load ruling M_1 , see table (fig. 17)
d_m [mm]	$(D + d)/2$ mean bearing diameter

The index f_1 for ball bearings and spherical roller bearings is – due to the curvature of the contact areas – in proportion to the expression $(P_{0^*}/C_0)^s$; for cylindrical roller bearings and tapered roller bearings f_1 remains constant. P_{0^*} represents the equivalent load (with dynamic forces), and C_0 represents the static load rating. The magnitude of the exponent s for ball bearings depends on the spinning friction component; for ball bearings with a low spinning friction, $s = 0.5$; for ball bearings with a high spinning friction, e.g. angular contact ball bearings with a contact angle of $\alpha_0 = 40^\circ$, $s = 0.33$, cp. Table (fig. 17).

17: Factors for the calculation of the load-dependent frictional moment component M_1

Bearing type, series	f_1 *)	P_1 1)
deep groove ball bearings	$(0.0005\dots 0.0009) \cdot (P_{0^*}/C_0)^{0.5}$	F_r or $3.3 F_a - 0.1 F_r^2$
self-aligning ball bearings	$0.0003 (P_{0^*}/C_0)^{0.4}$	F_r or $1.37 F_a/e - 0.1 F_r^2$
angular contact ball bearings		
single row, $\alpha = 15^\circ$	$0.0008 (P_{0^*}/C_0)^{0.5}$	F_r or $3.3 F_a - 0.1 F_r^2$
single row, $\alpha = 25^\circ$	$0.0009 (P_{0^*}/C_0)^{0.5}$	F_r or $1.9 F_a - 0.1 F_r^2$
single row, $\alpha = 40^\circ$	$0.001 (P_{0^*}/C_0)^{0.33}$	F_r or $1.0 F_a - 0.1 F_r^2$
double row or matched single row	$0.001 (P_{0^*}/C_0)^{0.33}$	F_r or $1.4 F_a - 0.1 F_r^2$
four point bearings	$0.001 (P_{0^*}/C_0)^{0.33}$	F_r or $1.5 F_a + 3.6 F_r^2$
cylindrical roller bearings with cage	$0.0002\dots 0.0004$	F_r^3
cylindrical roller bearings, full complement	0.00055	F_r^3
needle roller bearings	0.0015	F_r
tapered roller bearings, single row	0.0004	$2 Y F_a$ or F_r^2
tapered roller bearings, double row or two single-row ones in X or O arrangement	0.0004	$1.21 F_a/e$ or F_r^2
spherical roller bearings		
series 213, 222	$0.0005 (P_{0^*}/C_0)^{0.33}$	$1.6 F_a/e$, if $F_a/F_r > e$ $F_r \{1 + 0.6 [F_a/(e \cdot F_r)]^3\}$, if $F_a/F_r \leq e$
series 223	$0.0008 (P_{0^*}/C_0)^{0.33}$	
series 231, 240	$0.0012 (P_{0^*}/C_0)^{0.5}$	
series 230, 239	$0.00075 (P_{0^*}/C_0)^{0.5}$	
series 232	$0.0016 (P_{0^*}/C_0)^{0.5}$	
series 241	$0.0022 (P_{0^*}/C_0)^{0.5}$	
thrust ball bearings	$0.0012 (F_a/C_0)^{0.33}$	F_a
cylindrical roller thrust bearings	0.0015	F_a
spherical roller thrust bearings	$0.00023\dots 0.00033$	F_a where $F_r \leq 0.55 F_a$

*) the higher value applies to the wider series

1) Where $P_1 < F_r$, the equation $P_1 = F_r$ is used.

2) The higher of the two values is used.

3) Only radially loaded. For cylindrical roller bearings which also accommodate axial loads, the frictional moment M_1 has to be added to M_a : $M = M_0 + M_1 + M_a$, see fig. 18.

Symbols used:

P_{0^*} [N] equivalent load, determined from the dynamic radial load F_r and the dynamic axial load F_a as well as the static factors X_0 and Y_0 (see FAG catalogue WL 41420 EA, adjusted rating life calculation)

C_0 [N] static load rating (see FAG catalogue WL 41420 EA)

F_a [N] axial component of the dynamic bearing load

F_r [N] radial component of the dynamic bearing load

Y, e factors (see FAG catalogue WL 41420 EA)

The larger the bearings, the smaller the rolling elements in relation to the mean bearing diameter d_m . So the spinning friction between rolling elements and raceways increases underproportionally to d_m . With these formulas, large-size bearings, especially those with a thin cross section, feature higher frictional moments M_1 than are actually found in field application.

The load P_1 , which rules the load-dependent frictional moment M_1 , takes into account that M_1 changes with the load angle $\beta = \arctan(F_a/F_r)$. For the sake of simplification the axial factor Y was introduced as a reference value which also depends on F_a/F_r and on the contact angle α .

When determining the frictional moment of cylindrical roller bearings which also have to accommodate axial loads the axial load-dependent frictional moment component M_a has to be added to M_0 and M_1 . Consequently,

$$M = M_0 + M_1 + M_a \quad [\text{N mm}]$$

and

$$M_a = f_a \cdot 0,06 \cdot F_a \cdot d_m \quad [\text{N mm}]$$

f_a index, depending on the axial load F_a and the lubricating condition (fig. 18)

With these equations the frictional moment of a bearing can be assessed with adequate accuracy. In field applications certain deviations are possible if the aimed-at full fluid film lubrication cannot be maintained and mixed friction occurs. The most favourable lubricating condition is not always achieved in operation.

The breakaway torque of rolling bearings on start-up of a machine can be considerably above the calculated values, especially at low temperatures and in bearings with rubbing seals.

The frictional moment calculated for bearings with integrated rubbing seals increases by a considerable supplementary factor. For small, grease-lubricated bearings the factor can be 8 (e.g. 62012.RSR with standard grease after grease distribution), for larger bearings it can be 3 (e.g.

6216.2RSR with standard grease after grease distribution). The frictional moment of the seal also depends on the penetration class of the grease and on the speed.

The FAG measuring system R27 is also suitable for exactly determining the frictional moment of the sealing.

18: Coefficient of friction f_a for determining the axial load-dependent frictional moment M_a of axially loaded cylindrical roller bearings

The following parameters are required for determining M_a :

$f_b =$	0,0048 for bearings with a cage 0,0061 for full-complement bearings (without a cage)
d_m [mm]	mean bearing diameter = $0,5 \cdot (D + d)$
ν [mm ² /s]	operating viscosity of the oil or grease base oil
n [min ⁻¹]	inner ring speed
F_a [N]	axial loading
D [mm]	bearing O.D.
d [mm]	bearing bore

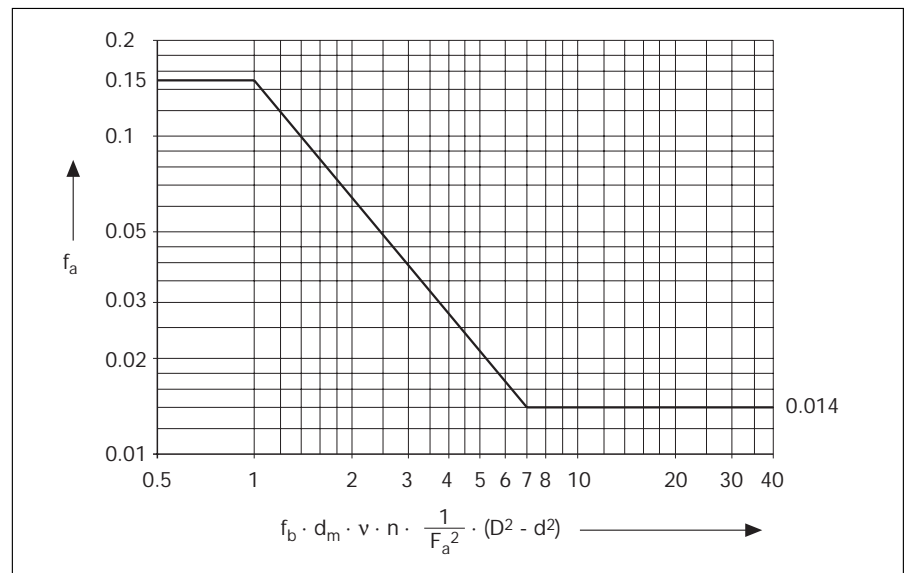

Lubricant in Rolling Bearings

Operating Temperatures

1.3 Operating temperature

The operating temperature of a bearing increases after start-up and remains constant when an equilibrium has been achieved between heat generation and heat emission (steady-state temperature).

The steady-state temperature t can be calculated based on the equation for the heat flow Q_R [W] generated by the bearing and the heat flow Q_L [W] which is dissipated into the environment. The bearing temperature t heavily depends on the heat transition between bearing, adjacent parts and environment. The equations are explained in the following. If the required data K_t and q_{LB} are known (possibly determined in tests), the bearing operating temperature t can be deduced from the heat balance equation.

The heat flow Q_R generated by the bearing is calculated from the frictional moment M [N mm] (section 1.2) and the speed n [min⁻¹].

$$Q_R = 1.047 \cdot 10^{-4} \cdot n \cdot M \text{ [W]}$$

The heat flow Q_L dissipated to the environment is calculated from the difference [K] between bearing temperature t and ambient temperature t_a , the size of the heat transfer surfaces ($2 d_m \cdot \pi \cdot B$) and the heat flow density q_{LB} customarily assumed for normal operating conditions (fig. 19) as well as the cooling factor K_t . For heat dissipation conditions found in the usual plummer block housings, $K_t = 1$, for cases where the heat dissipation is better or worse, see below.

$$Q_L = q_{LB} \cdot [(t - t_a)/50] \cdot K_t \cdot 2 \cdot 10^{-3} \cdot d_m \cdot \pi \cdot B \text{ [W]}$$

q_{LB} [kW/m²] rated heat flow density, see diagram, fig. 19

d_m [mm] $(D + d)/2$
 B [mm] bearing width

K_t cooling factor
 = 0.5 for poor heat dissipation (warm environment, external heating)
 = 1 for normal heat dissipation (self-contained bearing housing)
 = 2.5 for very good heat dissipation (relative wind)

With oil circulation lubrication, the oil dissipates an additional share of the heat. The dissipated heat flow $Q_{\dot{o}l}$ is the result of the inlet temperature t_E and the outlet temperature t_A , the density ρ and the specific heat capacity c of the oil as well as the amount of oil m [cm³/min]. The density usually amounts to 0.86 to 0.93 kg/dm³, whereas the specific entropy c – depending on the oil type – is between 1.7 and 2.4 kJ/(kg · K).

$$Q_{\dot{o}l} = m \cdot \rho \cdot c \cdot (t_A - t_E)/60 \text{ [W]}$$

For a standard mineral oil with $\rho = 0.89 \text{ kg/dm}^3$ and

$c = 2 \text{ kJ/(kg} \cdot \text{K)}$ the following simplified equation is used:

$$Q_{\dot{o}l} = 30 \cdot V_{\dot{o}l} \cdot (t_A - t_E) \text{ [W]}$$

where

$V_{\dot{o}l}$ amount of oil flowing through the bearing [l/min]

The bearing temperature t can be calculated as follows

$$Q_R = Q_L + Q_{\dot{o}l} \text{ [W]}$$

The result of such a temperature calculation is usually not accurate enough since the quantities entered into the calculation, especially q_L and K_t , are, as a rule, not accurately known. A useful basis is only obtained by determining the steady-state temperature in an operating test and then determining the cooling factor K_t on the basis of the steady-state temperature. Thus the steady-state temperatures of different bearing types under comparable mounting and operating conditions can be estimated with sufficient accuracy for different loads and speeds.

19: Bearing-specific rated heat flow density for the operating conditions: 70°C on the stationary bearing ring, 20°C ambient temperature, load 4...6 % of C_0

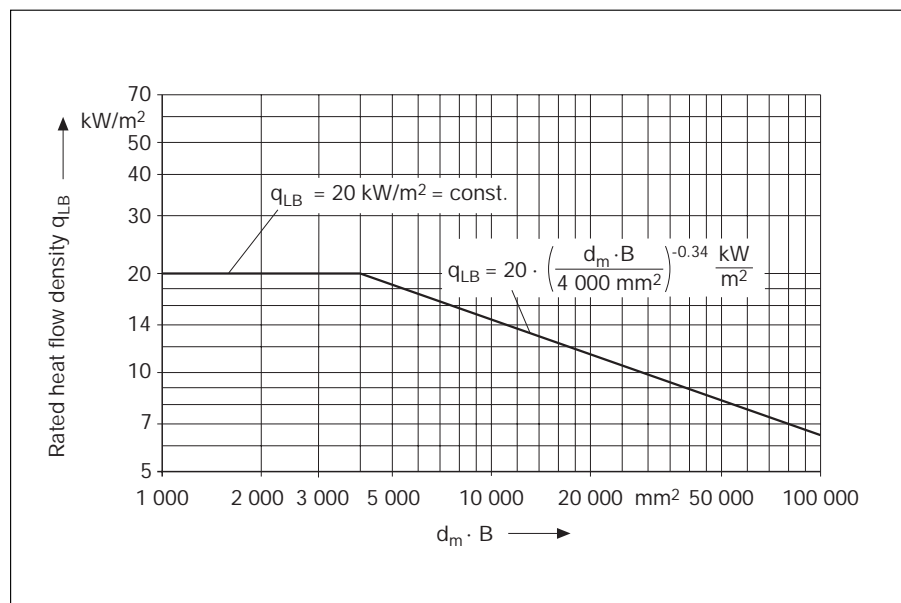

2 Lubricating System

When designing a new machine, the lubricating system for the rolling bearings should be selected as early as possible. It can be either grease or oil lubrication. In special cases, bearings are lubricated with solid lubricants. The table in fig. 20 gives a survey of the commonly used lubricating systems (page 20).

2.1 Grease Lubrication

Grease lubrication is used for 90 % of all rolling bearings. The main advantages of grease lubrication are:

- a very simple design
- grease enhances the sealing effect
- long service life with maintenance-free lubrication and simple lubricating equipment
- suitable for speed indexes $n \cdot d_m$ of up to $1,8 \cdot 10^6 \text{ min}^{-1} \cdot \text{mm}$ (n = speed, d_m = mean bearing diameter)
- at moderate speed indexes, grease can be used for some time until complete deterioration after its service life has terminated
- low frictional moment

With normal operating and environmental conditions, for-life grease lubrication is often possible.

If high stresses are involved (speed, temperature, loads), relubrication at appropriate intervals must be planned. For this purpose grease supply and discharge ducts and a grease collecting chamber for the spent grease must be provided, for short relubrication intervals a grease pump and a grease valve may have to be provided as well.

2.2 Oil Lubrication

Oil lubrication is recommended if adjacent machine components are supplied with oil as well or if heat must be dissipated by the lubricant. Heat dissipation can be necessary if high speeds and/or high loads are involved or if the bearing is exposed to extraneous heat.

Oil lubrication systems with small quantities of oil (throwaway lubrication), designed as drip feed lubrication, oil mist lubrication or oil-air lubrication systems, permit an exact metering of the oil rate required.

This offers the advantage that churning of the oil is avoided and the friction in the bearing is low.

If the oil is carried by air, it can be fed directly to a specific area; the air current has a sealing effect.

With oil jet or injection lubrication, a larger amount of oil can be used for a direct supply of all contact areas of bearings running at very high speeds; it provides for efficient cooling.

2.3 Dry Lubrication

For-life lubrication with solid or dry lubricants is achieved when the lubricant is bonded to the functional surfaces, e.g. as **sliding lacquers**, or when the lubricant layer wears down only slightly due to the favourable operating conditions. If **pastes** or **powders** are used as dry lubricants, the bearings can be relubricated. Excess lubricant, however, impedes smooth running.

With **transfer lubrication**, the rolling elements pick up small amounts of the solid lubricant and carry them into the contact area. The solid lubricant either revolves along with the rolling element set as a solid mass or is contained, in special cases, as an alloying constituent in the bearing cage material. This type of lubrication is very effective and yields relatively long running times. It ensures continuous relubrication until the solid lubricants are used up.

2.4 Selection of the Lubricating System

For the selection of a lubricating system the following points should be taken into account

- operating conditions for the rolling bearings

- requirements on running, noise, friction and temperature behaviour of the bearings
- requirements on safety of operation, i.e. safety against premature failure due to wear, fatigue, corrosion, and against damage caused by foreign matter having penetrated into the bearing (e.g. water, sand)
- cost of installation and maintenance of a lubricating system

An important precondition for high operational reliability are an unimpeded lubricant supply of the bearing and a permanent presence of lubricant on all functional surfaces. The quality of lubricant supply is not the same with the different lubricating systems. A monitored continuous oil supply is very reliable. If the bearings are lubricated by an oil sump, the oil level should be checked regularly to ensure high safety standards in operation.

Grease-lubricated bearings operate reliably if the specified relubrication intervals or, in the case of for-life lubricated bearings, the service life of the grease are not exceeded. If the lubricant is replenished at short intervals, the operational reliability of the bearing depends on the lubricating equipment functioning properly. With dirt-protected bearings, i.e. rolling bearings with two seals (e.g. Clean Bearings for oil-lubricated transmissions) operational reliability is ensured even after the grease has reached the end of its service life due to the lubricating effect of the oil.

Detailed information on the lubricating systems commonly used is provided in the table, fig. 20.

Lubricating System

Selection of the Lubricating System

20: Selection of Lubrication System

Lubricant	Lubrication systems	Lubricating equipment	Design measures	Index of attainable speed $n \cdot d_m$ in $\text{min}^{-1} \cdot \text{mm}^1$)	Suitable bearing types, operational behaviour
Dry lubricant	For-life lubrication	-	-	≈ 1500	Mainly deep groove ball bearings
	Relubrication	-	-		
Grease	For-life lubrication	-	-	$\approx 0,5 \cdot 10^6$ $\approx 1,8 \cdot 10^6$ for suitable special greases and bearings, lubrication intervals according to diagram fig. 33 (page 36)	All bearing types depending on rotational speed and grease type, with the exception of spherical roller thrust bearings. Special low friction and low noise greases
	Relubrication	Hand operated press, grease gun	Inlet holes, if necessary grease valve, collecting chamber for spent grease		
	Spray lubrication	Central lubricating plant ²⁾	Feed pipes or holes, collecting chamber for spent grease		
Oil (larger volumes)	Oil sump lubrication	Dipstick, tube, and level indicator	Housing space sufficient for certain oil volume, overflow outlet holes, connection for monitoring equipment	$\approx 0,5 \cdot 10^6$	All bearing types. Noise damping effect depending on oil viscosity; higher energy losses due to increased friction caused by churning, good cooling effect, discharge of wear particles by circulating oil and oil jet lubrication.
	Circulating oil lubrication due to pumping action of the bearings or special conveying elements		Oil supply holes, housing space sufficient for certain oil volume; conveying elements adapted to the oil viscosity and rational speed.	must be determined individually	
	Circulating oil lubrication	Circulation plant ²⁾	Sufficiently large oil inlet and outlet holes	$\approx 1 \cdot 10^6$	
	Oil jet lubrication	Circulation plant with nozzles ³⁾	Nozzles for direct oil injection, sufficiently large oil outlet holes	proven up to $4 \cdot 10^6$	
Oil (minimum volumes)	Intermittent drip oil lubrication Drip feed lubrication	Central lubricating plant ²⁾ , drip feed lubricator, oil spray lubrication equipment	Outlet holes	$\approx 2 \cdot 10^6$ depending on bearing type, oil viscosity, amount of oil, design	All bearing types. Noise damping effect depending on oil viscosity; friction depending on oil quantity and oil viscosity.
	Oil mist lubrication	Oil mist lubrication plant ³⁾ , if necessary oil separator	Extraction equipment, if necessary		
	Oil-air lubrication	Oil-air lubrication plant ⁴⁾	Extraction equipment, if necessary		

¹⁾ Depending on bearing type and mounting conditions.

²⁾ Central lubrication plant consisting of pump, reservoir, filters, pipelines, valves, flow restrictors. Circulation plant with oil return pipe, cooler if required (see figs. 21, 22).
Central lubricating plant with metering valves for small lubricant rates (5 to 10 mm³/stroke).

³⁾ Oil mist lubrication plant consisting of reservoir, mist generators, pipelines, recompressing nozzles, control unit, compressed air supply (see fig. 23).

⁴⁾ Oil-air lubrication system consisting of pump, reservoir, pipelines, volumetric air metering elements, nozzles, control unit, compressed air supply (see fig. 24).

⁵⁾ Number and diameter of nozzles (see fig 51, page 45).

2.5 Examples of the Different Lubrication Systems

2.5.1 Central Lubrication System

Fig. 21: It is used for throwaway lubrication and circulating lubrication. A pump, which is intermittently switched on by a control device, conveys oil or semi-fluid grease to the dosing valves. These valves deliver volumes of 5 to 500 mm³ per stroke.

One single pump supplies several bearing locations which require different amounts of lubricant with metered volumes of oil or semi-fluid greases, by setting feed cycles and volume to be delivered by the valve accordingly. For greases of penetration classes 2 to 3, dual-line pumping systems, progressive systems and multi-line systems are suitable. With multi-line systems, each of the pumping units supplies one bearing location with grease or oil.

21a: Schematic drawing of a central lubricating system (single-line system). 1 = pump, 2 = main pipe, 3 = dosing valve, 4 = secondary pipes to areas to be lubricated, 5 = lubricant exits, 6 = control device.
 21b: Dosing valve (example)

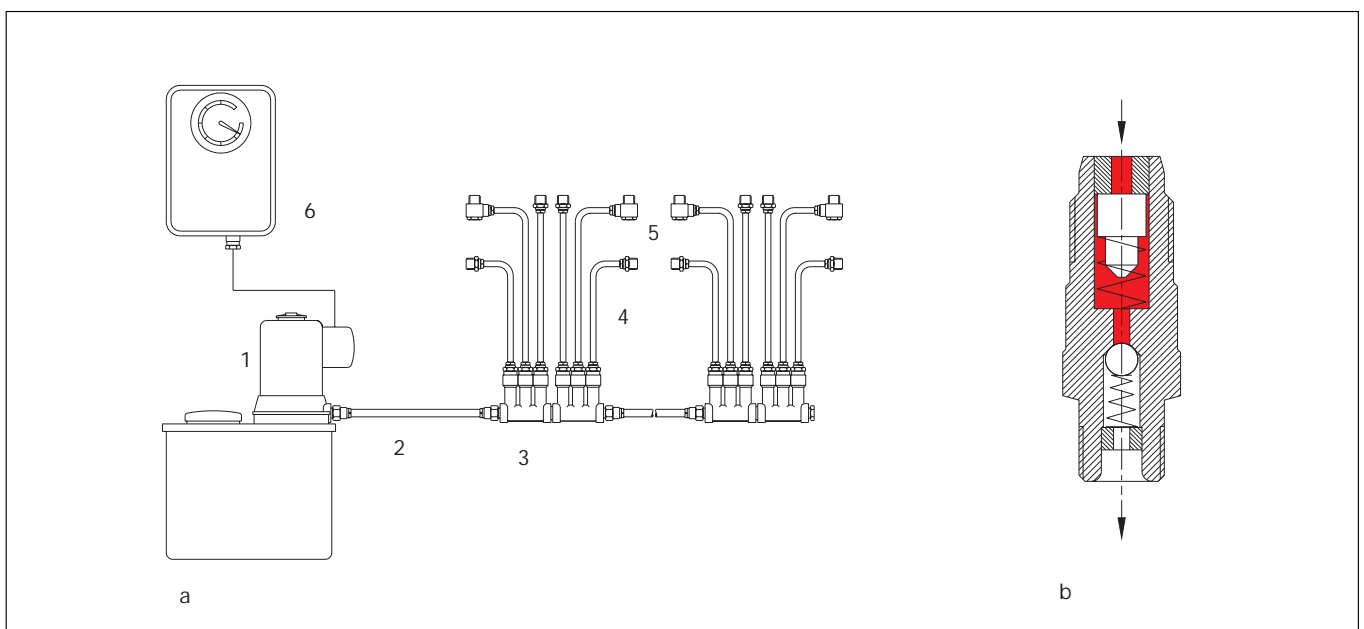

Lubricating System

Examples

2.5.2 Oil Circulation System

Fig. 22: If larger oil rates are needed for circulating lubrication, the oil can be distributed and delivered by flow restrictors because the oil volume fed to the bearings can vary slightly. Several litres of oil per minute can be delivered via the flow restrictors (cooling lubrication). According to the amount of oil required and the demands on operational reliability, the circulation system includes pressure limiting valve, cooler, filter, pressure gauge, thermometer, oil level control and reservoir heating. The oil flow rate of the bearing depends on the oil viscosity and consequently the oil temperature.

2.5.3 Oil Mist Lubrication System

Fig. 23: Compressed air, cleaned in an air filter, passes through a Venturi tube and takes in oil from an oil reservoir via a suction pipe. Part of the oil is atomized and carried on as mist and fine droplets. Larger drops not atomized by the air stream return to the oil reservoir. The drops in the oil mist are between 0.5 and 2 μm in size. The oil mist can be easily fed through pipes, but has poor adhesive properties. Therefore, the pipe terminates in a nozzle where the micronic oil particles form into larger droplets which are carried into the bearing by the air stream.

In some cases, the oil mist does not entirely form into droplets and is carried with the air out of the bearing into the environment. Oil mist is an air pollutant. Oils with viscosity grades of up to ISO VG 460 are used for oil mist lubrication. Tough oils must be heated so before atomizing that their viscosity is lower than 300 mm^2/s .

22a: Schematic drawing of a circulating system (example). 1 = reservoir, 2 = oil pump, 3 = pressure limiting valve, 4 = electric oil level control, 5 = cooler, 6 = thermometer, 7 = pressure gauge, 8 = filter, 9 = adjustable flow restrictor, 10 = lubricant exit, 11 = oil return pipe.

22b: Flow restrictor (example)

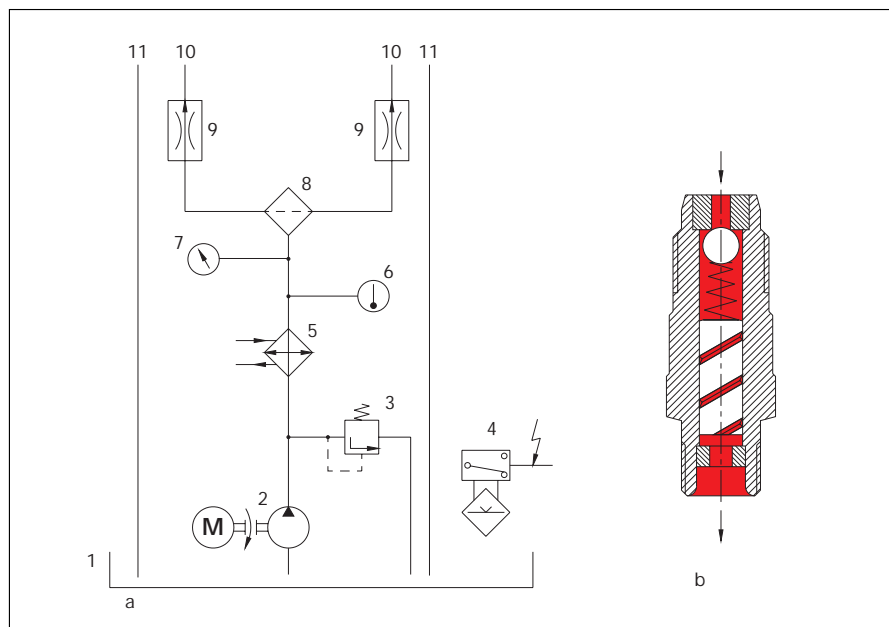

2.5.4 Oil-air lubrication system

Fig. 24: In an oil-air mixing unit (fig. 24b), oil is periodically added to an uninterrupted air stream via a metering valve. A control and monitoring unit switches on the oil pump intermittently. The injected oil is safely carried by the air current along the pipe wall to the bearing location. A transparent plastic hose is recommended as oil-air pipeline which permits the oil flow to be observed. The hose should have an inside diameter of 2 to 4 mm and a minimum length of 400 mm to ensure a continuous oil supply. Formation of oil mist is largely avoided. Oils of up to ISO VG 1500 (viscosity at ambient temperature approx. 7,000 mm^2/s) can be used. In contrast to oil mist lubrication, oil-air lubrication has the advantage that the larger oil particles adhere better to the bearing surfaces and most of the oil remains in the bearing. This means that only a small amount of oil escapes to the outside through the air vents.

23a: Schematic drawing of an oil mist lubrication system. 1 = air filter, 2 = air supply pipe, 3 = pressure control, 4 = pump, 5 = main pipe, 6 = atomizer, 7 = oil mist pipe, 8 = nozzles at point of lubrication, 9 = air pipe.

23b: Atomizer (Venturi tube)

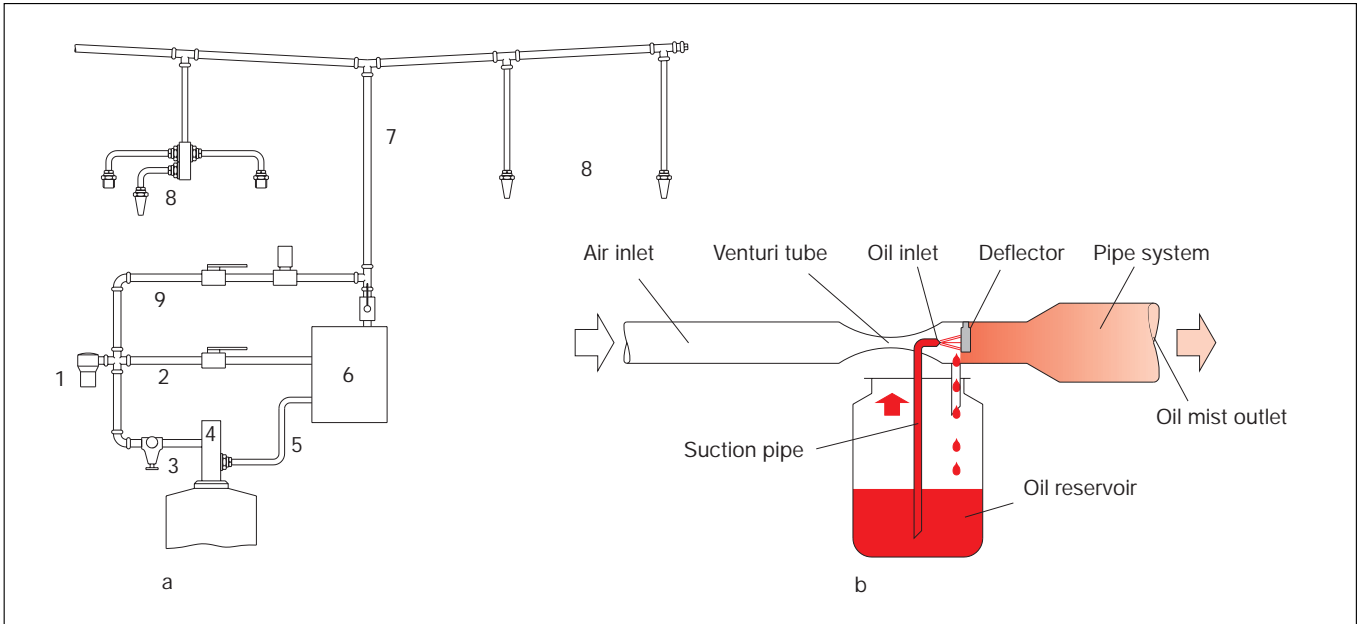

24a: Schematic drawing of an air-oil lubrication system (according to Woerner). 1 = automatic oil pump, 2 = oil pipe, 3 = air pipe, 4 = oil-air mixing unit, 5 = oil metering element, 6 = air metering element, 7 = mixing chamber, 8 = oil-air pipe.

24b: Oil-air mixing unit

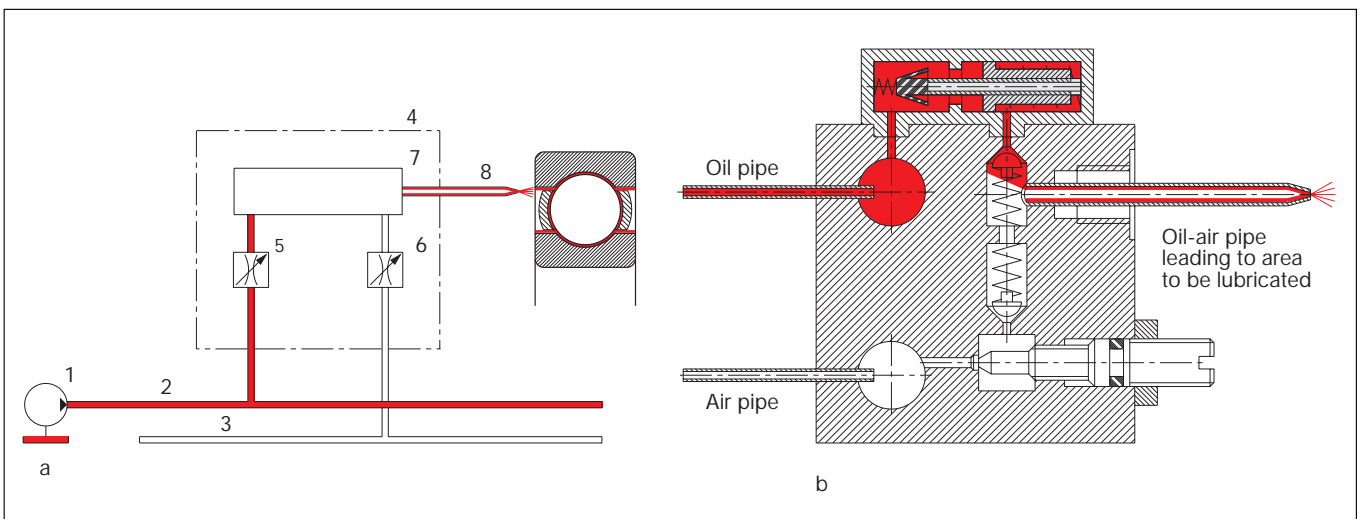

Lubricating System · Lubricant Selection

Examples

2.5.5 Oil and grease spray lubrication

The equipment required for spray lubrication is identical with the oil-air lubrication equipment. A control device opens a solenoid valve for air. The air pressure opens a pneumatic lubricant check valve for the duration of the spray pulse. By means of a central lubricating press, the lubricant is fed to the lubricant-

air mixing unit from where it is carried off by the air stream (fig. 25). The resulting spray pattern depends on the shape and size of the opening. An air pressure of 1 to 2 bar is required. Fine spray patterns are obtained with 1 to 5 bar. Greases of consistency classes 000 to 3 and oils up to ISO VG 1500 (viscosity at ambient temperature approximately 7000 mm²/s) can be sprayed.

25: Lubricant-air mixing unit

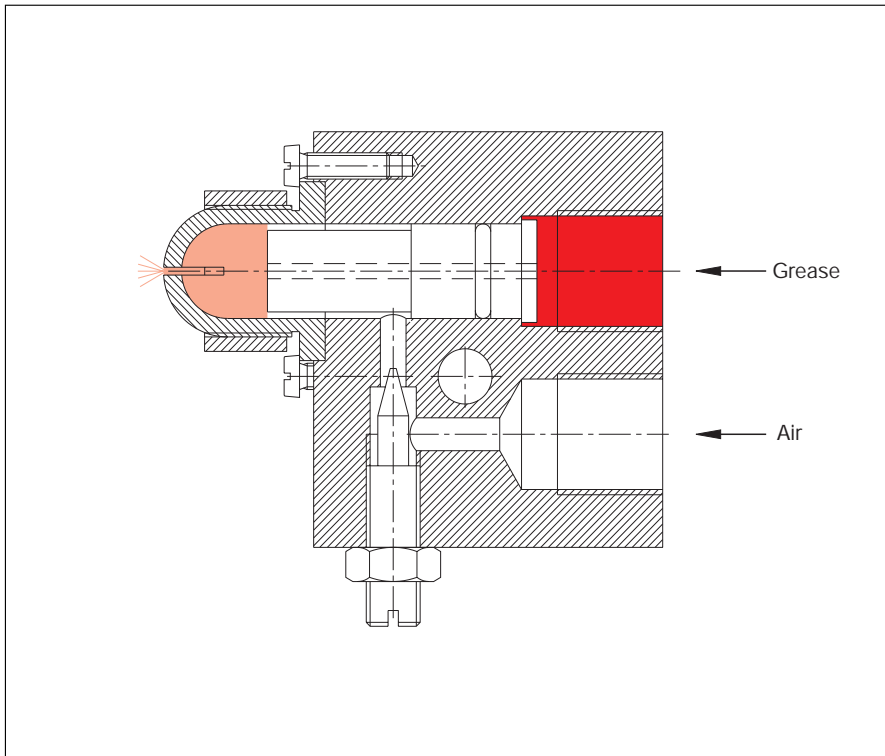

3 Lubricant Selection

Under most of the operating conditions found in field application, rolling bearings pose no special requirements on lubrication. Many bearings are even operated in the mixed-friction range. If, however, the capacity of the rolling bearings is to be fully utilized, the following has to be observed.

The greases, oils or solid lubricants recommended by the rolling bearing manufacturers meet the specifications for rolling bearing lubricants stated in the survey on page 25. Appropriately selected, they provide reliable lubrication for a wide range of speeds and loads.

Rolling bearing greases are standardized in DIN 51825. For instance, they must reach a certain life F_{50} at the upper operating temperature limit on the FAG rolling bearing test rig FE9 (DIN 51821).

Lubricants for the mixed friction range under high loads or with a low operating viscosity at high temperatures are evaluated on the basis of their friction and wear behaviour. Here, wear can be avoided only if separating boundary layers are generated in the contact areas, e.g. as a result of the reaction of additives with the metal surfaces due to high pressure and a temperature in the rolling contact area for which the additive is suitable. These lubricants are tested on FAG FE8 test rigs (E DIN 51819).

When using especially highly doped mineral oils, e.g. hypoid oils, and with synthetic oils, their compatibility with seal and bearing materials (particularly the cage material) must be checked.

26: Criteria for grease selection

Criteria for grease selection	Properties of the grease to be selected (see also section 3.1)
Operating conditions Speed index $n \cdot d_m$ Load ratio P/C	Grease selection according to diagram, fig. 28 (page 27) For high speed indices $d \cdot d_m$: consistency class 2-3, for high P/C load ratios: consistency class 1-2
Running properties Low friction, also during starting	Grease of penetration class 1 to 2 with synthetic base oil of low viscosity
Low constant friction at steady-state condition, but higher starting friction admissible	Grease of penetration class 3 to 4, grease quantity $\approx 30\%$ of the free bearing space or class 2 to 3, grease quantity $< 20\%$ of the free bearing space
Low noise level	Low-noise grease (high degree of cleanliness) of penetration class 2
Mounting conditions Inclined or vertical position of bearing axis	Grease with good adhesion properties of penetration classes 3 to 4
Outer ring rotating, inner ring stationary, or centrifugal force on bearing	Grease with a large amount of thickener, penetration classes 2 to 4 Grease fill quantity depending on speed
Maintenance Frequent relubrication	Soft grease of penetration class 1 to 2
Infrequent relubrication, for-life relubrication	Grease retaining its penetration class 2 to 3 under stressing, upper operating temperature limit higher than the operating temperature
Environmental conditions High temperatures, for-life lubrication	Heat resistant grease with synthetic base oil and heat resistant (e.g. synthetic) thickener
High temperature, relubrication	Grease which does not form any residues at high temperatures
Low temperature	Grease with low-viscosity base oil and suitable thickener, penetration class 1 to 2
Dusty environments	Stiff grease of penetration class 3
Condensate	Emulsifying grease, e.g. sodium or lithium soap base greases
Splash water	Water-repellent grease, e.g. calcium soap base grease of penetration class 3
Aggressive media (acids, bases, etc.)	Special grease, please consult FAG or lubricant manufacturer
Radiation	Up to absorbed dose rate $2 \cdot 10^4$ J/kg, rolling bearing greases to DIN 51 825, up to absorbed dose rate $2 \cdot 10^7$ J/kg, consult FAG.
Vibratory stressing	EP lithium soap base grease of consistency class 2, frequent relubrication. with moderate vibratory stresses, barium complex grease of consistency class 2 with solid lubricant additives or lithium soap base grease of consistency class 3.
Vacuum	Up to 10^{-5} mbar, depending on temperature and base oil, rolling bearing greases according to DIN 51 825, consult FAG.

Lubricant Selection

Grease

27: Grease properties

Grease type			Properties							
Thickener Type	Soap	Base oil	Temperature range °C	Drop point °C	Water resistance	Load carrying capacity	Price relation*	Suitability for rolling bearings	Remarks	
normal	aluminium calcium	mineral oil	-20...70	120	++	+	2.5...3	+	Swells with water	
			-30...50	80...100	+++	+	0,8	+	Good sealing action against water	
	lithium sodium	mineral oil	-35...130	170...200	+++	+	1	+++	Multipurpose grease	
			-30...100	150...190	-	++	0.9	++	Emulsifies with water	
lithium	PAO	ester	-60...150	170...200	+++	++	4...10	+++	For low and higher temperatures, high speeds	
	ester		-60...130	190	++	+	5...6	+++	For low temperatures, high speeds	
complex	aluminium barium calcium	mineral oil	-30...160	260	+++	+	2,5...4	+++	Multipurpose grease	
			-30...140	220	++	++	4...5	+++	Multipurpose grease, resistant to vapour	
			-30...140	240	++	++	0.9...1.2	+++	Multipurpose grease, may harden	
			-30...150	240	++	++	2	++	Multipurpose grease	
	lithium sodium	mineral oil	-30...130	220	+	+	3.5	+++	Multipurpose grease for high temperatures	
			-30...130	220	+	+	3.5	+++	Multipurpose grease for high temperatures	
	aluminium barium calcium	PAO	ester	-60...160	260	+++	++	10...15	+	For wide temperature range, good supply
				-60...160	220	+++	+++	15...20	+++	For low and higher temperatures, high speeds
				-60...160	240	+++	+++	15...20	+++	For low and higher temperatures, high speeds
				-40...180	240	++	+++	15	+++	For wide temperature range
barium calcium	ester	-40...130	200	++	++	7	+++	For low temperature and higher speeds		
		-40...130	200	+++	++	7	+++	at moderate loads		
lithium	ester	-40...180	240	++	+	10	+++	For especially wide temperature range		
		silicone oil	-40...180	240	++	-	20	++	For especially wide temperature range, P/C<0.03	
Bentonites	mineral oil PAO	-20...150	without	+++	+	2...6	++	For higher temperatures at low speeds		
		-50...180	without	+++	+	12...15	++	For wide temperature range		
Polyurea	mineral oil PAO	-25...160	250	+++	++	3	+++	For higher temperatures at medium speeds		
		-30...200	250	+++	+++	10	+++	High temperature grease with good long-term effectiveness		
	silicone oil fluoro-silicone oil	-40...200	250	+++	-	20	++	For high and low temperatures, low loads		
		-40...200	250	+++	+	100	+++	For high and low temperatures, moderate loads		
PTFE or FEP	alkoxy-fluoro oil fluoro-silicone-oil	-50...250	without	+++	++	100...150	+++	Both greases for very high and low temperatures		
		-40...200	without	+++	++	80...100	+++	Very good resistance to chemicals and solvents		

* reference grease: lithium soap base grease/mineral base oil =1
 +++ very good
 ++ good
 + moderate
 - poor

3.1 Selection of Suitable Greases

Lubricating greases are mainly distinguished by their main constituents, i.e. the thickener and the base oil. Usually, normal metal soaps are used as thickeners, but also complex soaps such as bentonite, polyurea, PTFE or FEP. Either mineral oils or synthetic oils are used as base oils. The viscosity of a base oil determines, together with the amount of thickener used, the consistency of the lubricating grease and the development of the lubricating film.

Like the lubricating oils, lubricating greases contain additives which improve their chemical or physical properties such as oxidation stability, protection against corrosion or protection from wear under high loads (EP additives).

The table in fig. 27 lists the principal grease types suitable for rolling bearing lubrication. The data contained in the table provides average values. Most of the greases listed are available in several penetration classes (worked penetration). Grease manufacturers supply the precise

data regarding the individual greases. The table provides some basic information for initial orientation.

More details on grease selection are given in the following text and in table 26 (page 25).

3.1.1 Grease Stressing by Speed and Load

The influence of speed and load on grease selection is shown in the diagram (fig. 28). The following parameters are needed for evaluation:

C	[kN]	dynamic load rating
P	[kN]	equivalent dynamic load acting on the bearing (for calculating, see FAG catalogue)
n	[min ⁻¹]	speed
d _m	[mm]	mean bearing diameter (D+d)/2
k _a		factor taking into account the sliding motion share of the bearing type

The diagram in fig. 28 is divided into three load ranges. For radial loads, the left-hand ordinate is used, for axial loads the right-hand one.

Rolling bearings operating under load conditions of **range N** can be lubricated with nearly all rolling bearing greases K according to DIN 51 825. Excluded are greases with an extremely low or high base oil viscosity, extremely stiff or soft greases, and some special greases, e.g. silicone greases, which can only be used up to loads of $P/C = 0,03$.

In the high speed and load range, that is in the upper right corner of range N, higher operating temperatures necessitate the use of thermally stable greases. The grease should be resistant to temperatures which are noticeably higher than the expected bearing operating temperature.

The loads in **range HL** are high. For these bearings greases with a higher base oil viscosity, EP additives, and, possibly, solid lubricant additives should be selected. In the case of high loads and low speed, these additives provide "chemical lubrication" or dry lubrication where the

28: Grease selection from the load ratio P/C and the relevant bearing speed index $k_a \cdot n \cdot d_m$

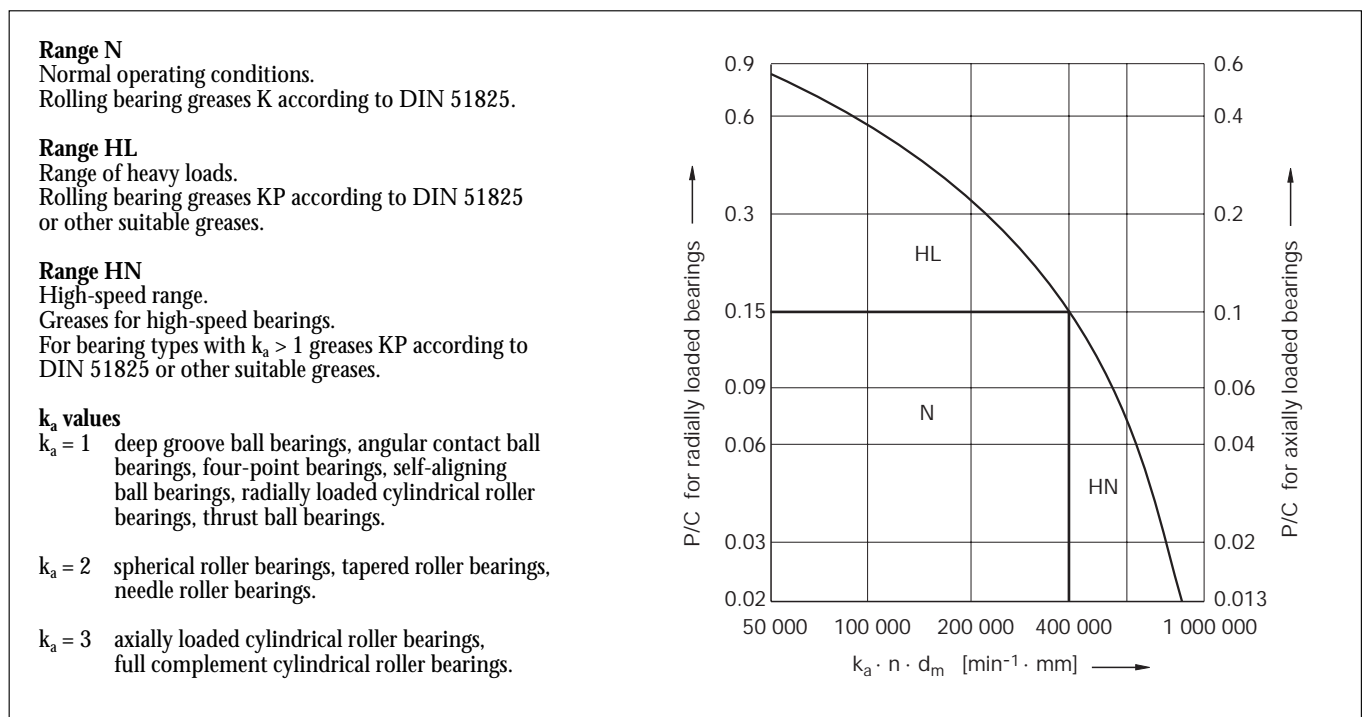

Lubricant Selection

Grease

lubricating film has been interrupted (mixed lubrication).

The stresses in **Range HN** are characterized by high speeds and low loads. At high speeds, the friction caused by the grease should be low, and the grease should have good adhesion properties. These requirements are met by greases with ester oil of low viscosity as base oil. Generally, the lower the base oil viscosity of a grease, the higher are the permissible speed indices recommended by the grease suppliers.

3.1.2 Running Properties

A low, constant friction is vital for bearings having to perform stick-slip free motions, such as the bearings for telescopes. For such applications EP lithium greases with a base oil of high viscosity and MoS₂ additive are used. Low friction is also required from bearings installed in machines whose driving power is primarily determined by the bearing friction to be overcome, as is the case with fractional HP motors. If such bearings start up rapidly from cold, they are best served by greases of consistency class 2 with a synthetic base oil of low viscosity.

At normal temperatures, low friction can be obtained by selecting a stiffer grease of consistency class 3 to 4, except for the short period of grease distribution. These greases do not tend to circulate in the bearing along with the bearing components if excess grease can settle in the housing cavities.

Lubricating greases for low-noise bearings must not contain any solid particles. Therefore these greases should be filtered and homogenized. A higher base oil viscosity reduces the running noise, especially in the upper frequency range.

The standard grease for low-noise deep groove ball bearings at normal temperatures is usually a filtered, lithium soap base grease of consistency class 2 with a base oil viscosity of approximately 60 mm²/s at 40 °C. FAG bearings which are as a standard fitted with dust shields or seals are filled with a particularly low-noise grease.

3.1.3 Special Operating and Environmental Conditions

High temperatures occur if the bearings are exposed to high stressing and/or high circumferential velocities and to extraneous heating.

For such applications, high-temperature greases should be selected. It must be taken into account that the grease service life is strongly affected if the upper temperature limit of the grease is exceeded (see 4.1.3). The critical temperature limit is approximately 70 °C for lithium soap base greases and approximately 80 to 110 °C for high-temperature greases containing a mineral base oil and a thermally stable thickener, depending on the grease type. High-temperature greases with a synthetic base oil can be used at higher temperatures than those with a mineral base oil because synthetic oils evaporate less and do not deteriorate so quickly. Greases with high-viscosity alkoxyfluoro oil as base oil are suitable for deep groove ball bearings up to a speed index of $n \cdot d_m = 140,000 \text{ min}^{-1} \cdot \text{mm}$, even at temperatures of up to 250 °C. At moderate temperatures, high-temperature greases can be less favourable than standard greases.

Occasionally, the bearings are lubricated, at high operating temperatures, with thermally less stable greases; in these cases, frequent relubrication is necessary. Greases must be chosen which do not solidify in the bearing thereby impairing the grease exchange and, possibly, causing the bearing to seize.

At **low temperatures**, a lower starting friction can be obtained with low-temperature greases than with standard greases. Low-temperature greases are lubricating greases with a low-viscosity base oil and lithium soap thickener. Multi-purpose greases, if used in the low-temperature range, are very stiff and, therefore, cause an extremely high starting friction. If, at the same time, bearing loads are low, slippage can occur resulting in wear on the rolling elements and raceways. The oil separation, and consequently the lubricating effect of standard greases, high-load greases and high-temperature greases, is clearly reduced at low temperatures.

The lower operating temperature limit of a grease is specified, in accordance with DIN 51 825, on the basis of its conveyability. This limitation does not mean that the bearing is sufficiently lubricated at this temperature. If, however, a certain minimum speed is combined with sufficient loading, the low temperature has usually no harmful effect. After a short running period, the temperature even of multi-purpose greases increases to normal values. After the grease has been distributed, the friction decreases to normal values.

Generally critical are, however, bearings which are operated under extreme cooling effect, especially if they rotate only occasionally or very slowly.

Condensate can form in the bearings and cause corrosion, if the machine operates in a humid environment, e.g. in the open air, and the bearings cool down during prolonged idle times of the machine. Condensate forms especially where there are large free spaces within the bearing or in the housing. In such cases, sodium and lithium soap base greases are recommended. Sodium grease absorbs large amounts of water, i.e. it emulsifies with water, but it may soften to such an extent that it flows out of the bearing. Lithium soap base grease does not emulsify with water so that, with suitable additives, it provides good protection against corrosion.

If the seals are exposed to **splash water**, a water-repellent grease should be used, e.g. a calcium soap base grease of penetration class 3. Since calcium soap base greases do not absorb any water, they contain an anti-corrosion additive.

Certain special greases are resistant to **special media** (boiling water, vapour, bases, acids, aliphatic and chlorinated hydrocarbons). Where such conditions are found, FAG should be consulted.

Grease, **acting as a sealing agent**, prevents contaminants from penetrating into the bearing. Stiff greases (consistency class 3 or higher) form a protective grease collar at the shaft passage, remain in the sealing gap of labyrinths and retain foreign particles. If the seals are of the rubbing type, the grease must also lubricate the surfaces of the sealing lip and the shaft which are in sliding contact. The

compatibility of the grease with the seal material has to be checked.

Radiation can affect the bearings, and consequently the grease as well, e.g. in nuclear power plants. The total absorbed dose is the measure for radiation stressing of the grease, that is either the radiation of low intensity over a long period of time or of a high intensity over a short period of time (absorbed dose rate). The absorbed dose rate must not, however, exceed a value of 10 J/kg · h. The consequences of stressing by radiation are a change in grease consistency and drop point, evaporation losses, and the development of gas. The service life of a grease stressed by radiation is calculated from $t = S/R$, unless the service life is still shorter due to other stresses. In this equation, t is the service life in hours, S the absorbed dose in J/kg permissible for the grease, and R the absorbed dose rate in J/(kg · h). Standard greases resist an absorbed dose of up to $S = 2 \cdot 10^4$ J/kg, especially radiation-resistant special greases resist an absorbed dose of up to $S = 2 \cdot 10^7$ J/kg with gamma rays (see also Glossary of Terms, heading "Radiation"). In the primary circle of nuclear power plants, certain substances such as molybdenum disulphide,

sulphur, halogenes) are subjected to strong changes. It must, therefore, be ensured that greases used in the primary circle do not contain these substances.

In the case of **vibratory stresses**, the grease is moved and displaced in and around the bearing which has the effect of frequent irregular regreasing of the contact surfaces; they can break down the grease into oil and thickener. It is good practice to select a grease from the table, fig. 26, and to relubricate the bearings at short intervals, e.g. once a week. Vibrationally stable multi-purpose greases of consistency class 3 have also proved to be suitable, for instance in vibration motors.

The base oil of the grease gradually evaporates in **vacuum**, depending on negative pressure and temperature. Shields and seals retain the grease in the bearing and reduce evaporation losses. The grease should be selected in accordance with table 26.

Inclined or vertical shafts can cause the grease to escape from the bearing due to gravity. Therefore, a grease with good adhesive properties of consistency class 3

to 4 should be selected in accordance with table 26 (page 25) which is retained in the bearing by means of baffle plates.

Where frequent **impact loads** or very high loads have to be accommodated, greases of consistency classes 1 to 2 of high base oil viscosity (ISO VG 460 to ISO VG 1500) are suitable. These greases form a thick, hydrodynamic lubricant film which absorbs shocks well and prevents wear better than a chemical lubrication achieved by means of EP additives. The drawback of greases with a high base oil viscosity is that, due to their slight oil separation, the effective presence of the lubricant has to be ensured by a large grease fill quantity or relubrication at short intervals.

Greases used for the purpose of **for-life lubrication** or **frequent relubrication** should be selected in accordance with the table, fig. 26 (page 25). The tables in figs. 26 and 27 help to specify the required properties of the lubricating grease based on the stresses listed there, so that a suitable FAG grease or a grease from the lists provided by the grease manufacturers can be selected. In cases of doubt, please consult FAG.

29: Effects of lubricant additives

Additives

Oxidation inhibitors
Corrosion inhibitors
Detergents
Dispersants

Popular lubricity improvers
Anti-wear and EP additives
Rust inhibitors
Metal deactivators
Pour point depressants
Viscosity index improvers
Defoamers

Effects of the additives

prevent premature formation of oxidation products
prevent corrosion of metal surfaces
remove oxidation products
keep sludge-forming insoluble compounds in suspension and prevent deposits on metal surfaces
Water is also held in suspension as a stable emulsion
reduce friction and wear during operation in the mixed friction range
reduce friction and wear, and the tendency towards seizure
prevent rust forming on metal surfaces during idle times
prevent action of metallic particles as catalysts in oxidation processes
reduce the pour point
reduce the decline of the viscosity curve with rising temperature
reduce foaming

Lubricant Selection

Grease · Oil

3.2 Selection of Suitable Oils

Both mineral and synthetic oils are generally suitable for the lubrication of rolling bearings. Lubricating oils based on mineral oils are the ones most commonly used today. These mineral oils must at least meet the requirements indicated in DIN 51501. Special oils, often synthetic oils, are used for extreme operating conditions or special demands on the stability of the oil under aggravating environmental conditions (temperature, radia-

tion etc.). Renowned oil manufacturers carry out successful FE8 tests themselves. The major chemico-physical properties of oils and information on their suitability are listed in table 30. The effects of additives are listed in table 29. Of particular importance are the additives for bearing operation in the mixed friction range.

3.2.1 Recommended Oil Viscosity

The attainable fatigue life and safety against wear increase, the better the con-

tact surfaces are separated by a lubricant film. Since the lubricant film thickness increases with rising oil viscosity, an oil with a high operating viscosity should be selected. A very long fatigue life can be reached if the operating viscosity $\lambda = \nu/\nu_1 = 3 \dots 4$, see diagrams 5 to 7. High-viscosity oils, however, also have drawbacks. A higher viscosity means higher lubricant friction; at low and normal temperatures, supply and drainage of the oil can cause problems (oil retention).

30: Properties of various oils

Oil type	Mineral oil	Polyalpha olefin	Polyglycol (water insoluble)	Ester	Silicone oil	Alkoxy fluoro oil
Viscosity at 40 °C [mm ² /s]	2...4500	15...1500	20...2000	7...4000	4...100 000	20...650
Max. temperature [°C] for oil sump lubrication	100	150	100...150	150	150...200	150...220
Max. temperature [°C] for circulating oil lubrication	150	200	150...200	200	250	240
Pour point [°C]	-20 ²⁾	-40 ²⁾	-40	-60 ²⁾	-60 ²⁾	-30 ²⁾
Flash point [°C]	220	230...260 ²⁾	200...260	220...260	300 ²⁾	-
Evaporation losses	moderate	low	moderate to high	low	low ²⁾	very low ²⁾
Resistance to water	good	good	good ²⁾ , hard to separate due to same density	moderate to good ²⁾	good	good
V-T-behaviour	moderate	moderate to good	good	good	very good	moderate to good
Suitability for high temperatures (≈ 150 °C)	moderate	good	moderate to good ²⁾	good ²⁾	very good	very good
Suitability for high loads	very good ¹⁾	very good ¹⁾	very good ¹⁾	good	poor ²⁾	good
Compatibility with elastomers	good	good ²⁾	moderate, to be checked when used with paint	moderate to poor	very good	good
Price comparison	1	6	4...10	4...10	40...100	200...800

¹⁾ with EP additives

²⁾ depending on the oil type

Therefore, the oil viscosity should be selected so that a maximum fatigue life is attained and an adequate supply of oil to the bearings is ensured.

In isolated cases, the required operating viscosity cannot be attained

- if the oil selection also depends on other machine components which require a thin-bodied oil,
- if, for circulating oil lubrication, the oil must be thin enough to dissipate heat and carry off contaminants from the bearing,
- if, in the case of temporarily higher temperatures or very low circumferential speeds, the required operating viscosity cannot be obtained even with an oil of the highest possible viscosity.

In such cases, an oil with a lower viscosity than recommended for the application can be used. It must, however, contain effective EP additives, and its suitability must have been proved by tests on the FAG test rig FE8. Otherwise, depending on the degree of deviation from the specified value, a reduced fatigue life and wear on the functional surfaces have to be expected as is proved by "attainable life" calculation. If mineral oils with an especially large amount of additives are used, the compatibility with sealing and cage materials has to be checked.

3.2.2 Oil Selection According to Operating Conditions

- Normal operating conditions: Under normal operating conditions (atmospheric pressure, max. temperature 100°C for oil sump lubrication and 150°C for circulating oil lubrication, load ratio $P/C < 0.1$, speeds up to limiting speed), straight oils and preferably inhibited oils can be used (corrosion and deterioration inhibitors, letter L in DIN 51 502). If the recommended viscosity values are not maintained, oils with suitable EP additives and anti-wear additives should be selected.

– High speed indices:

For high circumferential velocities ($k_a \cdot n \cdot d_m > 500\,000 \text{ min}^{-1} \cdot \text{mm}$), an oil should be used which is stable to oxidation, has good defoaming properties, and a positive viscosity-temperature behaviour whose viscosity decreases at a slower rate with rising temperature. Suitable synthetic oils with positive V-T behaviour are esters, polyalphaolefines and polyglycols. On starting, when the temperature is generally low, high churning friction and consequently high temperatures are avoided; the viscosity at steady-state temperature is sufficient to ensure adequate lubrication.

– High loads:

If the bearings are heavily loaded ($P/C > 0.1$) or if the operating viscosity ν is smaller than the rated viscosity ν_1 , oils with anti-wear additives should be used (EP oils, letter P in DIN 51 502). EP additives reduce the harmful effects of metal-to-metal contact which occurs in some places. The suitability of EP additives varies and usually depends largely on the temperature. Their effectiveness can only be evaluated by means of tests in rolling bearings (FAG test rig FE8).

– High temperatures:

The selection of oils suitable for high operating temperatures mainly depends on the operating temperature limit and on the V-T behaviour of the oil. The oils have to be selected based on the oil properties, see section 3.2.3.

3.2.3 Oil Selection According to Oil Properties

Mineral oils are stable only up to temperatures of approx. 150°C. Depending on the temperature and the period of time spent in the hot area, deterioration products form which impair the lubricating efficiency of the oil and settle as solid residual matter (oil carbon) in or near the bearing. Mineral oils are suitable to a limited extent only, if contaminated with water, even if they contain detergents to improve their compatibility with water. Although corrosion damage is avoided, the

water which is present in the form of a stable emulsion can reduce the service life of the oil and lead to increased formation of residues. The permissible amount of water can vary between a few per mil and several percent, depending on the oil composition and the additives.

Esters (diesters and sterically hindered esters) are thermally stable (–60 to +200 °C), have a positive V-T behaviour and low volatility and are, therefore, recommended for high speed indices and temperatures. In most cases, esters are miscible with mineral oils and can be treated with additives. The various ester types react differently with water. Some types saponify and split up into their various constituents, especially if they contain alkaline additives.

Polyalkylenglycols have a good V-T behaviour and a low setting point. They are, therefore, suitable for high and low temperatures (–50 to +200 °C). Due to their high oxidation stability oil exchange intervals in high-temperature operation can be twice to five times the usual interval for mineral oils. Most of the polyalkylenglycols used as lubricants are not water-soluble, and their ability to separate water is poor. Polyalkylenglycols are, as a rule, not miscible with mineral oils. Their pressure-viscosity coefficient is lower than that of other oils. Polyalkylenglycols may affect seals and lacquered surfaces in housings, and cages, for instance those made of aluminium.

Polyalphaolefins are synthetic hydrocarbons which can be used in a wide temperature range (–40 to +200°C). Due to their good oxidation stability, they attain a multiple of the life of mineral oils of similar viscosity under identical conditions. Polyalphaolefins have a positive viscosity-temperature behaviour.

Silicone oils (methyl phenyl siloxanes) can be used at extremely high and extremely low temperatures (–60 to +250 °C) because of their positive V-T behaviour; they have a low volatility and a high thermal stability. Their load carrying capacity, however, is low ($P/C \leq 0.03$), and their anti-wear properties are poor.

Lubricant Selection

Oil

Alkoxyfluorinated oils resist oxidation and water, but they are expensive. Their pressure-viscosity coefficient and density are higher than those of mineral oils of the same viscosity. They can be used at temperatures ranging from -30 to +240 °C.

Fire-resistant hydraulic fluids play a special role. For safety reasons, they have been used for many years in drift mining, on ships, in aeroplanes and fire-prone industrial plants. They are increasingly used for the following reasons:

- they are easier to dispose of than mineral oils
- price
- availability
- fire protection

Fire-resistant hydraulic fluids must meet various defined requirements concerning fire resistance, work hygiene and ecological safety. The different groups of fire-resistant hydraulic fluids are defined in the 7th Luxembourg Report, see table in fig. 31.

Typical applications:

The fluids of types HFA-E and HFA-S with up to 99 percent by volume of water are mainly used in chemical plants, hydraulic presses and in hydraulic long wall face working.

Fluids of type HFC with up to 45 percent by volume of water are mainly used in machines, e.g. in hydroloaders, drilling hammers and printing presses.

The synthetic HFD fluids are used in ropeway machines, shearer loaders, hydrostatic couplings, pumps and printing presses.

31: Classification of fire-resistant hydraulic fluids in accordance with the 7th Luxembourg Report and other characteristics

Fluid-group	Composition	ISO VG Class	Usual operating temperature range °C	Fire resistance	Density at 15 °C g/cm ³	Standards and specifications	Attainable a_{23} factor
HFA-E	Oil-in-water emulsion, max. emulsifying oil content is 20 percent by volume, usual content 1 to 5 percent by volume Concentrated fluids dissolved in water, usual content ≤ 10 percent by volume	no specification	+5 ... +55	very good	ca. 1	DIN 24 320	< 0.05
HFA-S							
HFB HFB-LT*	Oil-in-water emulsion, water content approx. 40 percent by volume	32, 46, 68, 100	+5 ... +60	good	0,92 ... 1,05		-
HFC	Aqueous polymer solution (polyglycols), water content at least 35 percent by volume	15, 22, 32, 46, 68, 100	-20 ... +60	very good	1,04 ... 1,09		< 0.2
HFD	Unhydrous fluids	15, 22, 32, 46, 68, 100	-20 ... +150	good	1,10 ... 1,45	VDMA 24317	
HFD-R	Phosphoric esters						< 0.8
HFD-S	Chlorinated hydrocarbons						< 0.5
HFD-T	Mixture of phosphoric esters and chlorinated hydrocarbons						< 1
HFD-U	other compounds						≤ 1 (z. B. synth. esters)

* LT indicates HFB fluids with a good emulsion persistence at low temperatures and which consequently are more suitable for longterm storage.

3.3 Selection of Dry Lubricants

Dry lubricants are of interest only in special cases, for instance where ceramic bearings are used or where oils and greases are unsuitable, e.g.:

- in vacuum where oil evaporates intensively
- under extremely high temperatures, e.g. kiln trucks used in the ceramic industry
- where oil or grease would be retained in the bearings only for a short period, e.g. blade bearings in controllable pitch blade fans which are exposed to centrifugal forces
- in nuclear and aerospace technology where the lubricant is exposed to intensive radiation

The most commonly used dry lubricants are graphite and molybdenum disulphide (MoS_2). They are applied as powders, bonded with oil as paste, or together with plastics material as sliding lacquer. Other solid lubricants are polytetrafluoroethylene (PTFE) and soft metal films (e.g. copper and gold) which are, however, used rarely.

The surfaces are usually bonderized to ensure better adhesion of the powder film. More stable films are obtained by applying sliding lacquer on bonderized surfaces. These sliding lacquer films can, however, be used only with small loads. Especially stable are metal films which are applied by electrolysis or by cathodic evaporation in an ultra high vacuum. It is advantageous to additionally treat the surface with molybdenum disulphide. The bearing clearance is reduced by four times the amount of the dry lubricant film thickness in the contact area. Therefore, bearings with larger-than-normal clearance should be used if dry lubrication is provided. The thermal and chemical stability of dry lubricants is limited.

Bearings operating at low velocities ($n \cdot d_m < 1\,500 \text{ min}^{-1} \cdot \text{mm}$) can be lubricated with molybdenum disulphide or graphite pastes. The oil contained in the

paste evaporates at a temperature of about 200°C leaving only a minute amount of residue. Rolling bearings with a velocity higher than $n \cdot d_m = 1\,500 \text{ min}^{-1} \cdot \text{mm}$ are in most cases lubricated with powder or sliding lacquer instead of pastes. A smooth powder film is formed by rubbing solid lubricant into the microscopically rough surface.

Graphite can be used for operating temperatures of up to 450°C as it is stable to oxidation over a wide temperature range. Graphite is not very resistant to radiation.

Molybdenum disulphide can be used up to 450°C . It keeps its good sliding properties even at low temperatures. In the presence of water, it can cause electrolytic corrosion. It is only little resistant to acids and bases.

The compatibility of **sliding lacquers** with the environmental agents has to be checked. Organic binders of sliding lacquers soften at high temperatures affecting the adhesive properties of the sliding lacquer. Inorganic lacquers contain inorganic salts as binder. These lacquers have a high thermal stability and do not evaporate in a high vacuum. The protection against corrosion, which is only moderate with all lacquers, is less with inorganic lacquers than with organic lacquers.

Pastes become doughy and solidify if dust penetrates into the bearings. In a dusty environment, sliding lacquers are better.

In special cases, rolling bearings can also be fitted with "self-lubricating" cages, i.e. cages with embedded dry lubricants or with a filling consisting of a mixture of dry lubricant and binder. The lubricant is transferred to the raceways by the rolling elements.

3.4 Quickly Biodegradable Lubricants

For some years now, lubricant manufacturers have offered a number of greases and oils for the lubrication of rolling

bearings some of which have a vegetable base oil (usually rapeseed oil); the majority, however, have a synthetic base oil (ester oils). Their biodegradability is tested in accordance with CED-L33-A93 and on the basis of DIN 51828. Usually, demands on them include a low water pollution class and often they must be non-deleterious to health as well. This often prevents effective doping.

Biodegradable lubricants on a vegetable oil base are suitable only for a limited range of temperatures.

Synthetic lubricants on an ester base, in contrast, offer a greater capacity and are approximately equal to lubricants with traditional base oils. Due to their biodegradability they are preferably used for throwaway lubrication, i.e. where spent lubricant can be discharged directly into the environment. Generally, a quality scatter similar to that of traditional lubricants can be assumed.

Lubricant Supply

Grease

4 Lubricant Supply

Rolling bearings need extremely little lubricant. In practical application, however, the bearings are supplied with a more ample amount of lubricant for the sake of operational reliability. However, too much lubricant in the bearing can have harmful effects. If excessive lubricant cannot escape from the bearing, churning or working cause the temperature to increase to such an extent that the lubricant can be impaired or even destroyed.

Generally, adequate lubricant supply is ensured by

- selecting the appropriate amount and distribution of lubricant within the bearing
- taking into account the lubricant service life, lubricant replenishment or exchange intervals
- the design of the bearing location
- the lubricating system and the related equipment (see table 20, page 20)

4.1 Grease Supply

4.1.1 Equipment

Only few lubricating tools, if any, are required for adequate bearing lubrication with grease. Unless greased by the manufacturer, the bearings are greased on mounting, generally by hand. In some cases, grease syringes or guns are used.

Equipment for relubrication is described in section 4.1.5.

4.1.2 Initial Grease Charge and Grease Renewal

For the greasing of bearings, the following instructions should be observed:

- Pack bearings to capacity with grease to ensure that all functional surfaces are supplied with grease.
- Fill the housing space on both sides of the bearing with grease to such an extent that it can still accommodate the grease expelled from the bearing. In this way no excessive amount of grease

will circulate through the bearing. If there is a major, empty housing space beside the bearing, the grease escaping from the bearing leaves the immediate bearing vicinity, and can no longer enhance the lubricating effect. In such a case, bearings with shields or seals should be used, or baffle plates should be provided to ensure that a sufficient amount of grease stays within the bearing. It is recommended to fill approx. 30% of the free bearing space with grease.

- Fill high-speed bearings, e.g. spindle bearings, only partially with grease (20 to 30% of the free space) to facilitate and accelerate the grease distribution during bearing start-up.
- Pack low-velocity bearings ($n \cdot d_m < 50,000 \text{ min}^{-1} \cdot \text{mm}$) and the housing cavities to capacity with grease. The lubricant friction due to working is negligible.

Deep groove ball bearings sealed on either side with seals (2RSR or 2RS) or shields (2ZR or 2Z) are supplied pre-

greased (see explanations on fig. 39, page 40). About 30% of the free bearing space is filled with grease. This amount is retained well inside the bearing even at high speed indices ($n \cdot d_m > 400,000 \text{ min}^{-1} \cdot \text{mm}$). For bearings running at even higher velocities, about 20% of the free bearing space is filled with grease. If sealed bearings are filled with more grease than specified above, the excess grease will escape more or less continuously until the normal grease fill is achieved.

Bearings with a rotating outer ring can retain, at high circumferential velocities, only an amount of grease which fills approx. 15% of the free bearing space.

Bearings filled with a suitable amount of grease will display a favourable frictional behaviour and lose only little grease.

With higher speed indices, bearing temperatures usually increase during the run-in period, occasionally even over several hours, fig. 32.

32: Frictional moment M_r and temperature ϑ of a freshly greased deep groove ball bearing

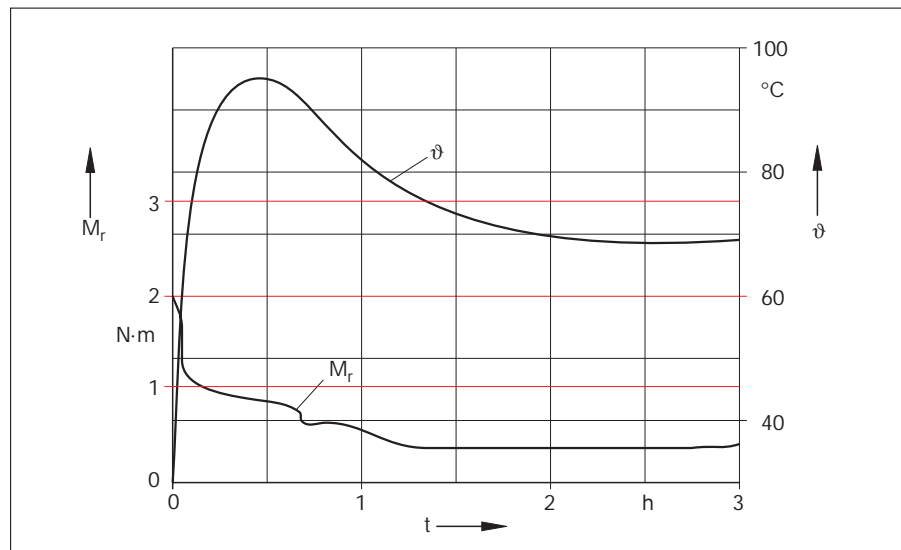

These effects are even more intensive, the larger the grease quantity in and beside the bearing and the more the movement of the grease out of the bearing is obstructed. They can be counteracted by an interval lubricant supply system with accordingly specified downtimes for cooling such as is used for spindle bearings in machine tools.

If for-life lubrication is required, the grease must be retained in or near the bearing by means of seals or baffle plates. Grease deposited in the bearing vicinity can result in longer lubrication intervals because, at increased temperatures, the external grease separates oil which contributes, at least in part, to bearing lubrication, and, due to vibrations, fresh grease from the housing is occasionally fed into the bearing (relubrication).

If high temperatures are to be expected near a bearing it is recommendable to provide some extra grease beside the bearing with as large an oil-separating area towards the bearing as possible. This can be achieved, for instance, by means of an angular baffle plate, fig. 40 (page 40). The amount of extra grease should ideally be 3 to 5 times that of the normal grease fill quantity and should be located either on one side of the bearing or, better, equally divided to the right and to the left of the bearing.

If the pressure on one side of the bearing differs from that on the other side, the grease, and the separated base oil, are likely to be expelled from the bearing. Also, dirt can penetrate into the bearing. In such cases openings and holes must be machined into the surrounding structure for pressure compensation.

4.1.3 Grease Service Life

The grease service life is the period from start-up until the failure of a bearing as a result of lubrication breakdown. It is determined by the

- amount of grease
- type of grease (thickener, base oil, additives)

- bearing type and size
- amount and type of loading
- speed index
- bearing temperature
- mounting conditions

The service life of greases is determined by laboratory tests, e.g. with the FAG rolling bearing grease test rig FE9. Such tests must be carried out on a statistical basis since, even under comparable test conditions (identical operating parameters, bearings of the same quality, identical grease quantity), depending on the type of grease used, a scatter of the grease life values of up to 1:10 must be taken into account. Therefore, the calculation of the grease service life values is based on a certain failure probability, similar to the calculation of the bearing fatigue life. The grease service life F_{10} of a certain grease applies to a failure probability of 10%.

4.1.4 Lubrication Intervals

Lubrication intervals are defined as the minimum grease service life F_{10} of standard greases which meet the minimum requirements of DIN 51 825. Upon expiry of the lubricating interval at the latest, the bearing has to be regreased or lubricated, see section 4.1.5.

Diagram 33 shows the lubrication interval t_f for standard lithium soap base greases for the usual field applications under favourable environmental conditions. It applies to lithium soap base greases of penetration classes 2–3 and operating temperatures of up to 70 °C (measured at the outer ring), which are lower than the limiting temperature of the grease, and a mean bearing load corresponding to $P/C < 0.1$.

In the case of higher bearing loads or temperatures, the lubrication intervals are shorter.

At temperatures of 70 °C and up (limiting temperature), the lubrication intervals for lithium soap base greases with a

mineral base oil is reduced to $f_3 \cdot t_f$. The limiting temperatures for sodium and calcium soap base greases are 40 to 60 °C, those of high-temperature greases are 80 to 100 °C or higher.

Diagram 33 shows the lubrication intervals as a function of $k_f \cdot n \cdot d_m$. Different k_f values apply to the individual bearing types. Where ranges of k_f values are indicated, the higher values apply to the heavier series, and the lower values to the lighter series of a bearing type.

Compared to the grease service life achieved under ideal conditions, fig. 33 takes into account certain safety margins for the lubrication interval under favourable operating conditions. Rolling bearing users assume the lubrication interval if the grease service life F_{10} of the grease used is not known. If the capacity of a grease is to be utilized fully, one can assume, for ideal operating conditions, the grease service life F_{10} , which was determined in tests, or one orients oneself by experimental values.

Poor operating and environmental conditions reduce the lubrication interval. The reduced lubrication interval t_{fq} is obtained from the equation

$$t_{fq} = t_f \cdot f_1 \cdot f_2 \cdot f_3 \cdot f_4 \cdot f_5 \cdot f_6$$

The reduction factors f_1 to f_6 are explained in table 34 (page 37).

With gap-type seals, an air current passing through the bearing considerably reduces the lubrication interval. The air current deteriorates the lubricant, carries oil or grease from the bearing and conveys contaminants inside the bearing.

A grease of a high base oil viscosity ($v_{40} \geq 400 \text{ mm}^2/\text{s}$) separates only little oil, especially at low temperatures. Therefore, its use requires short lubrication intervals. Contaminants (including water) penetrating through the seals also affect the grease service life.

An overall reduction factor q which takes into account all poor operating and environmental conditions (table 35 on page 37) can be applied to certain bearing applications. The reduced lubrication interval t_{fq} is obtained from

$$t_{fq} = q \cdot t_f$$

Lubricant Supply

Grease

In the case of unusual operating and environmental conditions (high or low temperatures, high loads, high circumferential velocities) the use of special greases appropriate for these operating conditions usually result in the lubrication intervals shown in diagram 33.

The lubrication interval reduction factors f_1 , f_2 , f_3 and f_6 generally apply to special greases as well. The reduction factors taking into account load and temperature, f_3 and f_4 , as well as the relevant limiting temperatures will be indicated by the lubricant manufacturers – for Arcanol greases by FAG upon inquiry.

4.1.5 Relubrication, Relubrication Intervals

Grease replenishment or exchange is required if the grease service life is shorter than the anticipated bearing life.

The bearings are relubricated by means of grease guns through lubricating nipples. If frequent relubrication is required, grease pumps and volumetric metering units must be used (central lubrication system, grease spray lubrication, see pages 21 and 24). It is essential that the fresh grease displaces the spent grease so that the grease is exchanged, but over-greasing is prevented.

If the lubrication intervals determined in accordance with figs. 33 to 35 are noticeably exceeded, a higher rate of bearing failures due to starved lubrication must be taken into account, depending on the grease quality. Therefore, grease renewal or replenishment must be scheduled in time. Grease renewal intervals should be shorter than the reduced lubrication intervals t_{fq} .

33: Lubrication intervals under favourable environmental conditions. Grease service life F_{10} for standard lithium soap base grease according to DIN 51825, at 70 °C, failure probability 10 %.

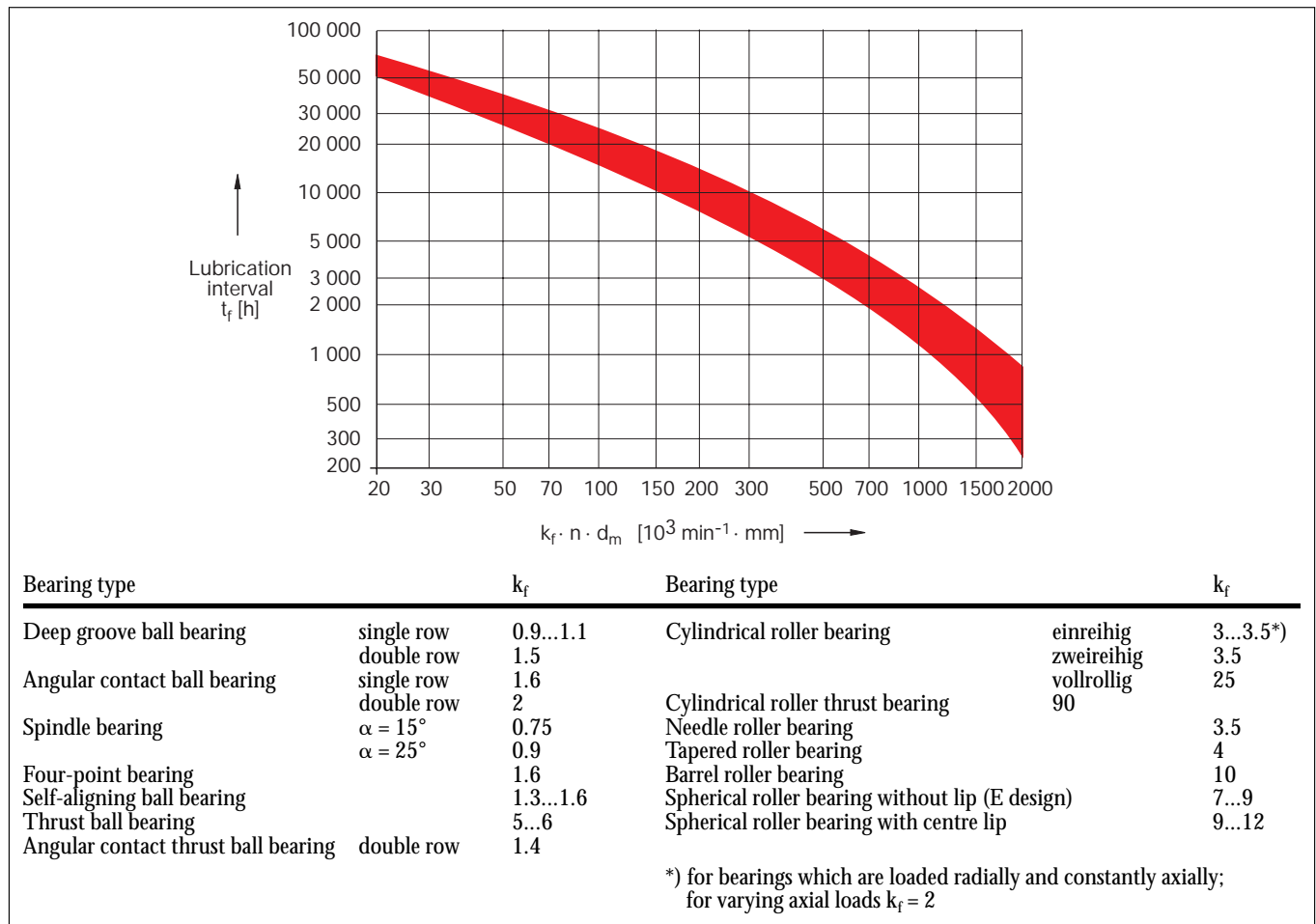

34: Reduction factors f_1 to f_6 for poor operating and environmental conditions

Effect of dust and moisture on the bearing contact surfaces

moderate	$f_1 = 0.9...0.7$
strong	$f_1 = 0.7...0.4$
very strong	$f_1 = 0.4...0.1$

Effect of shock loads and vibrations

moderate	$f_2 = 0.9...0.7$
strong	$f_2 = 0.7...0.4$
very strong	$f_2 = 0.4...0.1$

Effect of high bearing temperature

moderate (up to 75 °C)	$f_3 = 0.9...0.6$
strong (75 to 85 °C)	$f_3 = 0.6...0.3$
very strong (85 to 120 °C)	$f_3 = 0.3...0.1$

Effect of high loads

P/C = 0.1...0.15	$f_4 = 1.0...0.7$
P/C = 0.15...0.25	$f_4 = 0.7...0.4$
P/C = 0.25...0.35	$f_4 = 0.4...0.1$

Effect of air current passing through the bearing

slight current	$f_5 = 0.7...0.5$
strong current	$f_5 = 0.5...0.1$

Centrifugal effect or vertical shaft depending on the sealing

$$f_6 = 0.7...0.5$$

35: Overall reduction factors q for certain applications

	Dust moisture	Shocks vibrations	High running temperature	Heavy loads	Air current	Factor q
Stationary electric motor	-	-	-	-	-	1
Tailstock spindle	-	-	-	-	-	1
Grinding spindle	-	-	-	-	-	1
Surface grinder	-	-	-	-	-	1
Circular saw shaft	•	-	-	-	-	0.8
Flywheel of a car body press	•	-	-	-	-	0.8
Hammer mill	•	-	-	-	-	0.8
Dynamometer	-	-	•	-	-	0.7
Axle box roller bearings for locomotives	•	•	-	-	-	0.7
Electric motor, ventilated	-	-	-	-	•	0.6
Rope return sheaves of aerial ropeway	••	-	-	-	-	0.6
Car front wheel	•	•	-	-	-	0.6
Textile spindle	-	•••	-	-	-	0.3
Jaw crusher	••	••	-	•	-	0.2
Vibratory motor	•	•••	•	-	-	0.2
Suction roll (paper making machine)	•••	-	-	-	-	0.2
Press roll in the wet section (paper making machine)	•••	-	-	-	-	0.2
Work roll (rolling mill)	•••	-	•	-	-	0.2
Centrifuge	•	-	-	••	-	0.2
Bucket wheel reclaimer	•••	-	-	•	-	0.1
Saw frame	•	•••	-	-	-	<0.1
Vibrator roll	•	•••	•••	-	-	<0.1
Vibrating screen	•	•••	-	-	-	<0.1
Slewing gear of an excavator	••	-	-	•••	-	<0.1
Pelleting machine	•	-	•	•••	-	<0.1
Belt conveyor pulley	•••	-	-	•	-	<0.1

• = moderate effect

•• = strong effect

••• = very strong effect

Lubricant Supply

Grease

In most cases, it is difficult to remove the spent grease entirely from the bearing when **relubricating** it. Consequently, the relubrication intervals must be shorter (usual relubrication intervals 0.5 to 0.7 t_{iq}). The appropriate amounts of grease for replenishment are shown in fig. 36.

36: Grease relubrication quantities

Relubrication quantity m_1 for weekly to yearly relubrication

$$m_1 = D \cdot B \cdot x \text{ [g]}$$

Relubrication	x
weekly	0.002
monthly	0.003
yearly	0.004

Quantity m_2 for extremely short relubrication intervals

$$m_2 = (0,5...20) \cdot V \text{ [kg/h]}$$

Relubrication quantity m_3 prior to restarting after several years of standstill

$$m_3 = D \cdot B \cdot 0,01 \text{ [g]}$$

$$V = \text{free space in the bearings}$$

$$\approx \pi/4 \cdot B \cdot (D^2 - d^2) \cdot 10^{-9} - G/7800 \text{ [m}^3\text{]}$$

$$\approx \pi/4 \cdot B \cdot (D^2 - d^2) \cdot 10^{-9} - G' \cdot 0.4536/7800 \text{ [m}^3\text{]}$$

- d = bearing bore diameter [mm]
- D = bearing outside diameter [mm]
- B = bearing width [mm]
- G = bearing weight [kg]
- G' = bearing weight [lb]

Replenishment is required where the used grease cannot be removed during relubrication (no empty housing spaces, no grease escape bores, no grease valve). The amount of grease supplied should be limited to prevent overgreasing.

Large relubrication amounts are recommended with large free housing spaces, grease valves, grease escape bores, or with low speeds corresponding to $n \cdot d_m \leq 100\,000 \text{ min}^{-1} \cdot \text{mm}$. In such cases, the risk of temperature increases due to working of the grease is reduced.

Ample grease amounts improve the exchange of used grease for fresh grease and contribute to the sealing against the ingress of dust and moisture. Relubrication with the bearing rotating at operating temperature is favourable.

Grease renewal is recommended for long lubrication intervals. This is largely achieved by pressing in a greater amount of grease than that which is in the bearing, thereby expelling the spent grease. A particularly large amount of grease is required if, due to high temperatures, the old grease has been damaged to some degree. In order to drain as much of the used grease as possible by flushing, an amount of up to three times the grease quantity indicated in fig. 36 is used for relubrication. Not all greases are suitable for this flushing. Suitable greases are recommended by the lubricant manufacturers. The grease exchange is facilitated by a grease feed and flow which ensures uniform grease exchange over the bearing circumference. Design examples are shown in figs. 42 to 46. During grease exchange, the grease must be able to escape easily to the outside or into a space of sufficient size for the accommodation of the spent grease.

Very short relubrication intervals are required if stressing is very high ($n \cdot d_m > 500\,000 \text{ min}^{-1} \cdot \text{mm}$; $P/C > 0,3$; $t > 140 \text{ }^\circ\text{C}$; or combinations of lower values). Under such conditions, the use of a grease pump is justified. Care must be taken that the grease in the bearing, housing and feed pipe maintains a pumpable consistency. At extremely high temperatures, the grease may solidify, obstructing the passage of fresh grease and resulting in blocking of the metering valves.

The **escaping grease can act as a sealing agent** if small quantities are continuously supplied at short intervals. The relubrication quantities supplied per hour can be half the amount to several times the amount of grease which the cavities of the bearing can hold. By applying the quantities m_2 recommended in fig. 36 for extremely short relubrication intervals, the grease escapes at a rate of 2 cm per day or more depending on the sealing gap width.

If **temperatures are high**, either a cheap grease which is stable only for a short period, or an expensive, thermally stable grease can be used. When using the former greases, relubrication quantities of 1 to 2% of the free bearing space per hour have proved appropriate. With thermally stable and very expensive special greases, significantly smaller amounts will do. With such small quantities, however, direct grease supply into the bearing is absolutely essential. Small relubrication quantities are also possible with high circumferential velocities. They increase the frictional moment and the temperature only slightly. Also, they are less harmful to the environment. They do, however, require more maintenance and complicated lubricating equipment. Very small grease quantities can be supplied to specific locations by means of grease spray lubrication (fig. 25, page 24).

A **mixture of different grease types** often cannot be avoided. Mixtures which have proved to be relatively safe are those of greases with identical soap bases. The basic miscibility of oils and greases is indicated in the tables in figs. 37 and 38.

If incompatible greases are mixed, their structure can change drastically, and the greases may even soften considerably. If a different grease type is selected deliberately, the old grease should be flushed out with a large amount of the new grease, provided this can be done with the existing design of the bearing location. Another supply of the new grease should be pressed in after a relatively short period of time.

37: Miscibility of oils

Base oils	Mineral oil	Polyalphaolefin	Ester oil	Polyglycol oil	Silicone oil (methyl)	Silicone oil (phenyl)	Polyphenyl-ether oil	Alkoxy-flourinated oil
Mineral oil	+	+	+	²⁾	-	0	0	-
Polyalphaolefin	¹⁾	+	+	²⁾	-	0	0	-
Ester oil	¹⁾	+	+	0	-	0	+	-
Polyglycol oil	²⁾	²⁾	0	+	-	-	-	-
Silicone oil (methyl)	-	-	-	-	+	+	-	-
Silicone oil (phenyl)	0	0	0	²⁾	+	+	+	-
Polyphenyl-ether oil	¹⁾	¹⁾	¹⁾	²⁾	-	¹⁾	+	-
Alkoxyfluorinated oil	-	-	-	-	-	-	-	+

+ may be mixed

0 usually compatible, must be checked for specific application

- must not be mixed

¹⁾ miscible; however, bearings shall not be relubricated with a lubricant of an inferior capacity than the original lubricant

²⁾ generally not compatible, must be checked for specific application

38: Miscibility of lubricating greases

Thickener Original grease	Thickener relubrication grease							Bentonite/Hectorite	Polyurea	PTFE
	(Li)thium-soap	(Li)thium-complex soap	(So)dium soap	(So)dium-complex soap	(Ca)lcium complex soap	(Ba)rium complex soap	(Al)uminium complex soap			
(Li)thium soap	+	+	-	0	0	0	-	-	0	-
(Li)thium complex soap	¹⁾	+	-	0	0	0	0	-	0	-
(So)dium soap	-	-	+	+	0	0	-	-	+	-
(So)dium complex soap	-	0	¹⁾	+	0	0	0	-	0	-
(Ca)lcium complex soap	¹⁾	0	-	0	+	+	0	-	0	-
(Ba)rium complex soap	¹⁾	0	-	0	+	+	0	-	0	-
(Al)uminium complex soap	¹⁾	0	-	0	0	0	+	-	0	-
Bentonite/Hectorite	-	0	-	0	0	0	-	+	0	-
Polyurea	¹⁾	0	-	0	0	0	-	-	+	-
PTFE	-	-	-	-	-	-	-	-	-	+

+ generally well compatible

0 usually compatible, must be checked for specific application

- generally not compatible

¹⁾ miscible; however, bearings shall not be relubricated with a lubricant of an inferior capacity than the original lubricant

Lubricant Supply

Grease

4.1.6 Examples of Grease Lubrication

Fig. 39: Structures can be uncomplicated if sealed and pre-greased rolling bearings are used. Depending on the application, shields or seals can be used singly or in combination with a preseal. Rubbing seals (designs RSR or RS) increase the bearing temperature due to the seal friction. Shields (ZR or Z) and non-rubbing seals (RSD) form a gap with the inner ring and do not add to the friction. The standard grease for deep groove ball bearings sealed on either side is a lithium soap base grease of consistency class 2 or 3, the softer grease being used for small bearings. Approx. 30% of the free bearing space is filled with grease. Under normal operating and environmental conditions, this amount of grease is sufficient for a long service life. The grease is distributed during a short run-in period and settles mainly on the inner surfaces of the shields or seals, which form an undisturbed area. After the grease has settled, circulation is negligible, and the bearing

runs at low friction. Upon completion of the run-in period, friction is only 30 to 50 % of the starting friction.

Fig. 40: The deep groove ball bearing is sealed on one side. On the other side, a grease deposit is formed by means of a baffle plate. Thus a major amount of grease is near the bearing but not inside it. At high temperatures, the grease deposited separates oil which lubricates the deep groove ball bearing adequately and over a long period. In this way a longer life is reached during which additional lubricant friction need not be taken into account. FAG will indicate suitable greases on inquiry.

Fig. 41: A baffle plate prevents the grease from escaping from bearings with grease pumping or conveying effect or with a vertical axis. Especially for bearing types which have a high rate of sliding friction and an intensive grease pumping or conveying effect (e.g. tapered roller bearings), a baffle plate is advantageous at higher speeds, though not always sufficient. Grease supply can be further im-

proved by short lubrication intervals.

Fig. 42: The grease is fed into the bearing through a lubricating groove and several lubricating holes in the bearing outer ring. The direct and symmetrical grease feeding ensures a uniform supply to the two rows of rollers. Spaces or grease discharge holes of sufficient size must be provided to allow the spent grease to be expelled on either side.

Fig. 43: The spherical roller bearing is relubricated from one side. During relubrication, grease escapes from the opposite side. Grease escape bores or grease valves prevent the retention of grease when replenishment of large quantities is required. During the run-in period, the temperature rises for one or several hours (about 20 to 30 K above the operating temperature). Grease type and consistency play a large part in determining the pattern of the temperature curve.

Fig. 44: If a grease valve is provided, there is a risk – with rather long relubrication intervals, high circumferential velocities and a pumpable grease – that only

39: Sealed bearings greased by the rolling bearing manufacturer

40: A grease deposit can form between the baffle plate and the bearing

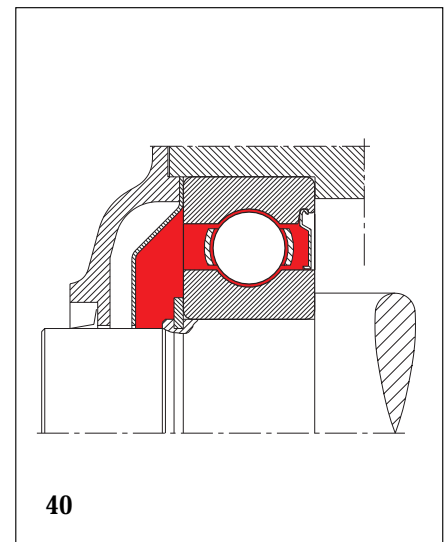
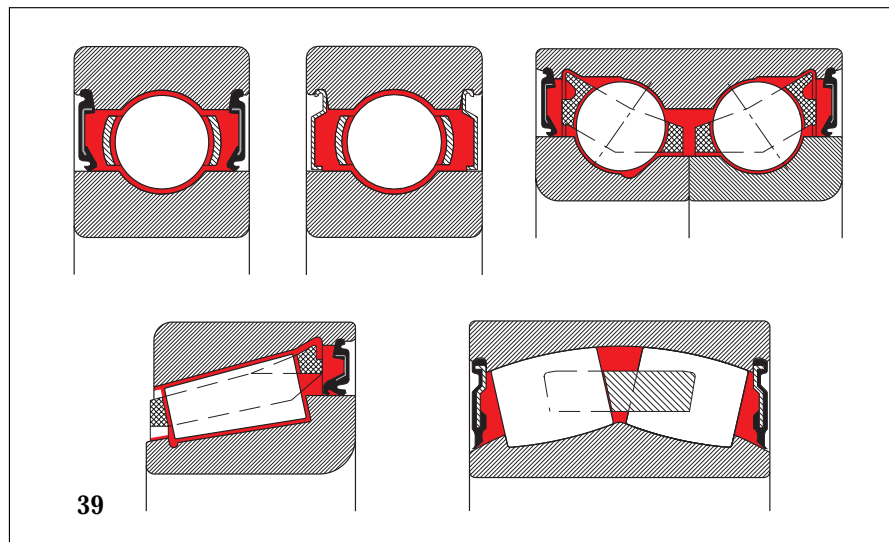

little grease remains in the bearing at the side facing the grease valve. This can be avoided by displacing the gap between the rotating grease valve and its stationary counter part nearer to the shaft. A normal grease valve where the gap is at bearing outer ring level (fig. 44a) has a strong

pumping effect. The pumping effect is moderate if the gap is positioned at bearing pitch circle level (fig. 44b), and the pumping effect is practically zero if the gap is at inner ring level (fig. 44c). The grease valve then acts as a baffle plate and retains the grease in the bearing.

41: A baffle plate retains the grease inside and near the bearing.

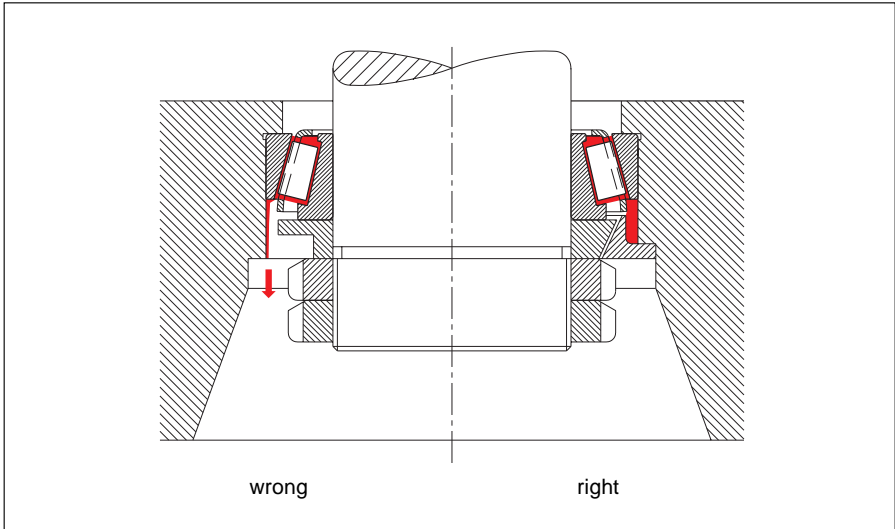

44: The pumping effect of the grease valve depends on the washer diameter.

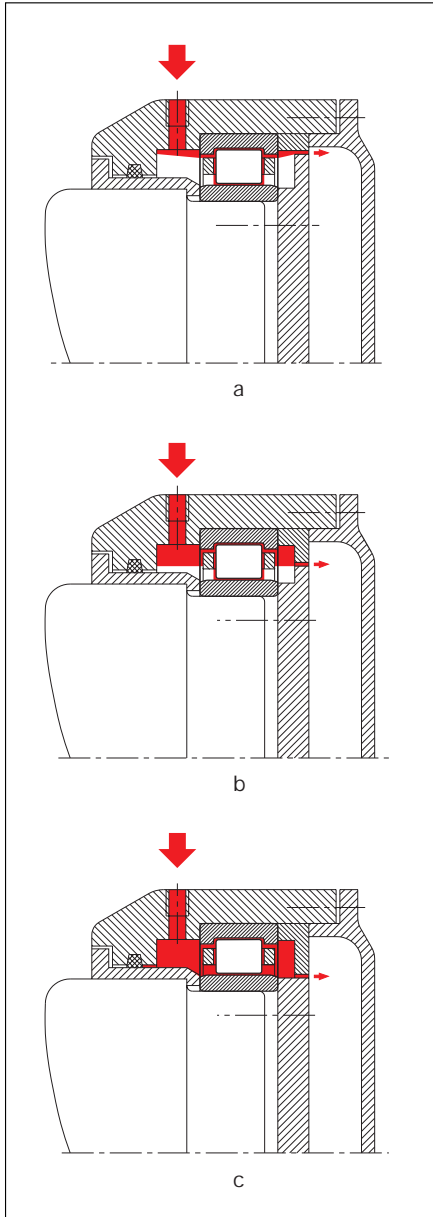

42: The grease is fed through the bearing outer ring.

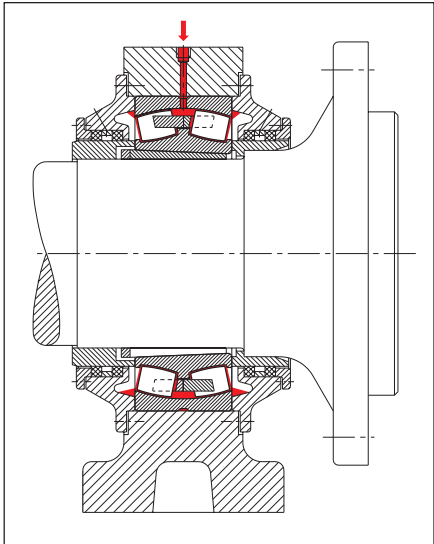

43: Relubrication. Overlubrication is prevented by the escape bore.

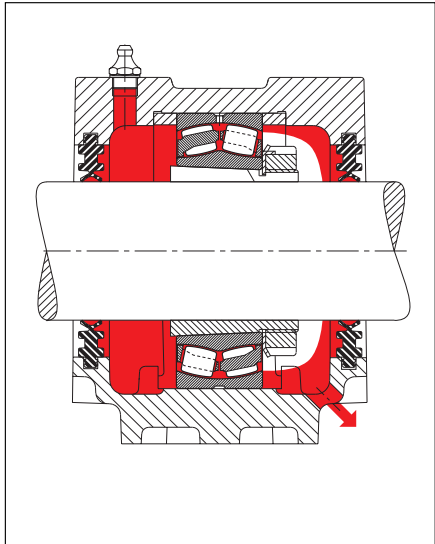

Lubricant Supply

Grease

Fig. 45: The relubricating grease is pressed through hole S in disk Z directly between the cage and outer ring. The spent grease is pushed by the fresh grease into space F between bearing and cover; it must be regularly emptied through opening B. On mounting, chamber K on the right bearing side is packed with grease in order to improve sealing. The bearing is best relubricated while stationary. Holes S should be distributed on disk Z in such a way that the grease is uniformly supplied to the bearing thereby effectively displacing the spent grease. Holes S in disk Z which are located close to filling hole C must therefore be spaced at a greater distance than the diametrically opposed holes for a uniform distribution of the grease on the bearing circumference. This ensures uniform flow resistance; the new grease expels the used grease evenly from the bearing. Large quantities of fresh grease help displace the old grease.

Fig. 46: A pair of angular contact ball bearings is supplied with fresh grease through lubricating holes in the spacer between the bearings. Trapping of grease is avoided by introducing the grease at the small inner ring diameter from where centrifugal forces convey it via the large diameter to the outside. Only bearings with an asymmetrical cross section, i.e. angular bearings and tapered roller bearings, produce this conveying effect. If a bearing pair with a symmetrical cross section is relubricated between the two bearings, grease valves or escape holes should be provided on both sides of the pair. It is important that the resistance the escaping grease meets with is roughly the same everywhere. Otherwise, grease will escape mainly on the side where it meets with less resistance, and starved lubrication threatens on the other side.

These examples show that a functional grease guidance usually involves some expense. Therefore, such grease guidance is provided preferably where expensive machines or difficult operating conditions such as high speeds, loads, or temperatures are involved. In these cases, replacement of the spent grease must be ensured, and overgreasing must be ruled out. For normal applications, no such expense is required; this is proved by dependable bearing arrangements flanked by batches of grease on both sides of the bearings. They gradually separate oil for lubricating the contact areas and provide extra protection against contaminants which might otherwise penetrate into the bearings. However, when the bearings are relubricated one cannot be certain that the fresh grease reaches all contact areas. Since contaminants may penetrate into the bearings on these occasions, it is better in such cases to provide for-life lubrication instead. On the occasion of machine overhauling, the bearings can be dismantled, washed, and filled with fresh grease.

45: Direct supply of grease from the side through holes in a feed disk

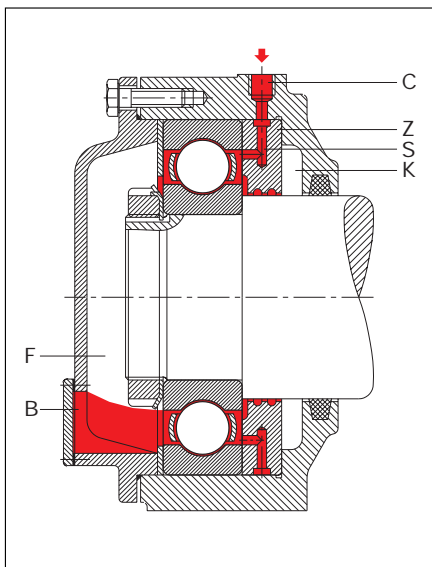

46: The grease is supplied between a bearing pair.

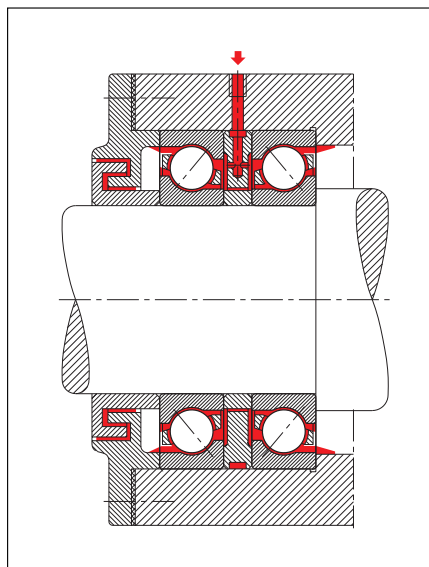

4.2 Oil Supply

4.2.1 Lubricating Equipment

Unless oil sump lubrication is provided, the oil must be fed to the bearing locations by means of lubricating devices depending on the lubrication system selected. Large and smaller oil volumes are fed to the bearings by means of pumps, small and very small oil volumes are supplied by oil-mist, oil-air, and central lubrication plants. The oil volume can be measured by means of metering elements, flow restrictors and nozzles. Detailed information on the most commonly used lubrication systems is provided in chapter 2 "Lubrication System".

4.2.2 Oil Sump Lubrication

In an oil sump or, as it is also called, an oil bath, the bearing is partly immersed in oil. When the shaft is in the horizontal position, the bottom rolling element should be half or completely covered when the bearing is stationary, fig. 47.

When the bearing rotates, oil is conveyed by the rolling elements and the cage and distributed over the circumference. For bearings with an asymmetrical cross section which, due to their geometry, have a pumping effect, oil return holes or ducts should be provided to ensure circulation of the oil. If the oil level rises above the bottom roller and, especially, if circumferential velocities are high, the friction due to churning raises the bearing temperature and can cause foaming. At speed indices of $n \cdot d_m < 150\,000 \text{ min}^{-1} \cdot \text{mm}$, the oil level may be higher. If complete immersion of a bearing in the oil sump cannot be avoided, as is the case with the shaft in the vertical position, the friction moment doubles or triples depending on the oil viscosity. As a rule, oil sump lubrication can be used up to a speed index of $n \cdot d_m = 300\,000 \text{ min}^{-1} \cdot \text{mm}$; if the oil is renewed frequently, a speed index of up to $500\,000 \text{ min}^{-1} \cdot \text{mm}$ is possible. At a speed index of $n \cdot d_m = 300\,000 \text{ min}^{-1} \cdot \text{mm}$ and above, the bearing temperatures often exceed 70°C . The oil sump level should be checked regularly.

The **oil renewal schedule** depends on contamination and ageing of the oil.

Ageing is accelerated by the presence of oxygen, rubbed-off metal particles (catalyst) and high oil temperatures. The alteration of the neutralization number NZ and the saponification number VZ indicate to oil manufacturers and engineers to what degree the oil has deteriorated.

Under normal conditions, the oil renewal intervals indicated in fig. 48 should be observed. It is important that the bearing temperature does not exceed 80°C and that contamination due to foreign particles and water is low. As the diagram shows, frequent oil changes are necessary if the oil volume is small. During the run-in period, an early oil change may be required due to the higher temperature and heavy contamination by wear particles. This applies particularly to rolling bearings lubricated together with gears. Increasing content of solid and liquid foreign particles often require premature oil renewal. The permissible amount of solid foreign particles depends on the size and hardness of the particles, see also section 5.1.1 "Solid Foreign Particles", page 54).

The permissible amount of water in the oil depends on the oil type, and will

47: Oil level in an oil sump

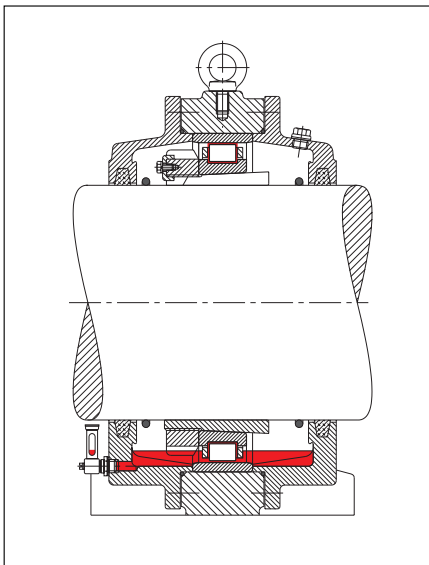

48: Oil volume and renewal interval vs. bearing bore

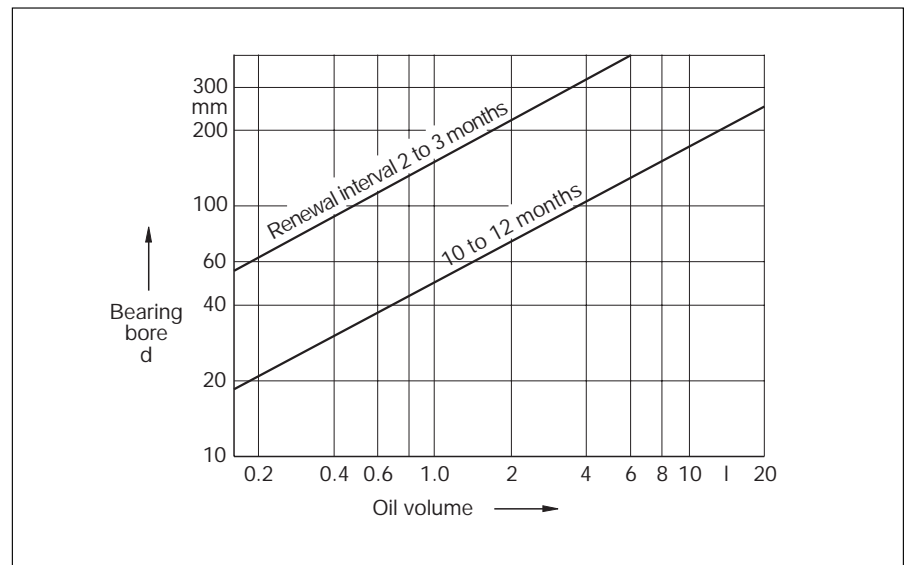

Lubricant Supply

Oil

be indicated by the oil manufacturers upon inquiry. Water in the oil leads to corrosion, accelerates oil deterioration by hydrolysis, forms aggressive substances together with the EP additives, and affects the formation of a load carrying lubricating film. Water which has entered the bearing through the seals or condensate having formed in the bearing must be rapidly separated from the oil; an oil with positive water separation ability is advantageous. Water is separated by treating the oil in a separator or by evaporation in a vacuum. The separation of water and oil is, however, difficult with polyglycol oils, because their density is approximately 1. Therefore, the water does not settle in the oil reservoir; at oil temperatures above 90 °C the water evaporates.

For extreme applications it is advisable to determine the oil change intervals individually based on repeated oil analyses. It is good practice to analyse the oil after

one to two months and, depending on the results of the first analysis, to determine, after a certain period, the neutralization number NZ, the saponification number VZ, the content of solid foreign particles and water, and the viscosity of the oil. The service life of a bearing can be drastically reduced by the constant presence of even little water in the oil. The degree of deterioration and contamination can be roughly estimated by comparing a drop each of fresh and used oil on a sheet of blotting paper. Major differences in colour are indicative of oil deterioration or contamination.

4.2.3 Circulating Lubrication with Average and Above Average Oil Volumes

Having passed through the bearings, the oil is collected in an oil reservoir and

recirculated to the bearings. If oil circulation lubrication is provided, a filter is imperative to screen out wear particles and contaminants, see also section 5.1.3. The negative effect of contaminants on the attainable life is described in more detail in section 1.1.3.

The **oil volume** required depends on the operating conditions. Diagram 49 shows the quantities which, at viscosity ratios of $\kappa = \nu/\nu_1$ of 1 to 2.5, generate a moderate flow resistance in the bearing. Only a small amount of oil is required for lubricating the bearings. In comparison, the quantities indicated in diagram 49 as being sufficient for lubrication (line a) are large. These oil volumes are recommended to ensure appropriate lubrication of all contact areas even if the oil supply to the bearings is inadequate, i.e. oil is not fed directly into the bearings. The minimum volumes indicated are used for lubrication if low friction is required. The result-

49: Oil volumes for circulating lubrication

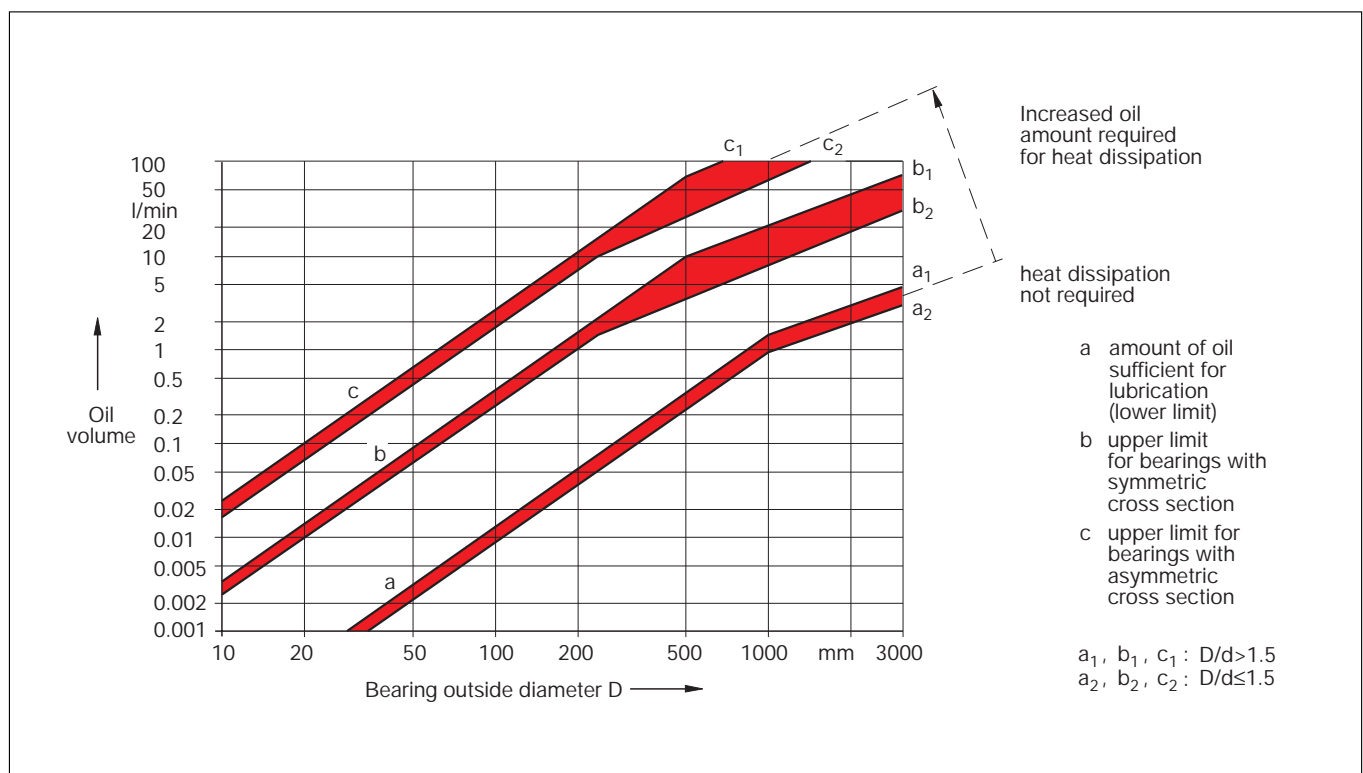

ing temperatures are the same as with oil sump lubrication.

If heat dissipation is required, larger oil volumes are provided. Since every bearing offers a certain resistance to the passage of oil, there are upper limits for the oil volume. For bearings with an asymmetrical cross section (angular contact ball bearings, tapered roller bearings, spherical roller thrust bearings) larger flow rates are permissible than for bearings with a symmetrical cross section, because their flow resistance is lower due to their pumping action. For the oil volumes indicated in diagram 49, oil supply and retention at the feed side is supposed to take place without pressure up to an oil level of just below the shaft. The oil volume required for a specific application in order to ensure a sufficiently low bearing temperature depends on the conditions of heat generation and dissipation. The required oil volume can be determined by

recording the bearing temperatures during machine start-up and setting it accordingly.

The flow resistance of bearings with a symmetrical cross section increases with rising circumferential velocity. If, in this case, larger oil volumes are required, the oil is injected directly between cage and bearing ring.

Oil jet lubrication reduces the energy losses due to churning. Diagram 50 shows the recommended oil volumes for oil jet lubrication versus the speed index and the bearing size. The diameter and number of nozzles are indicated in diagram 51. Oil entrapment in front of the bearing is prevented by injecting the oil into the bearings where free passage is assured. Discharge ducts with sufficient diameter allow the oil not absorbed by the bearing and the oil flow through the bearing to drain freely (figs. 62 and 63).

For the high circumferential velocities usual with oil jet lubrication, oils with an operating viscosity of $\nu = 5$ to $10 \text{ mm}^2/\text{s}$ ($\lambda = 1$ to 4) have proven their efficiency. The diagrams in fig. 52 show the oil volume Q and the jet velocity v for a nozzle length of $L = 8.3 \text{ mm}$, operating viscosities of 7.75 and $15.5 \text{ mm}^2/\text{s}$ and different nozzle diameters as a function of the pressure drop Δp .

This data was determined in tests. The oil flow rate through bearings rotating at high speed decreases as speed increases. It increases with increasing injection velocity, with 30 m/s being a sensible upper limit.

Rolling bearings must be **lubricated before going into operation**. With circulating oil lubrication, this is achieved by starting the oil pump before the machine is put into operation. This is not necessary where provisions have been made to ensure that the oil is not entirely drained

50: Recommended oil volume for oil jet lubrication

51: Diameter and number of nozzles for oil jet lubrication

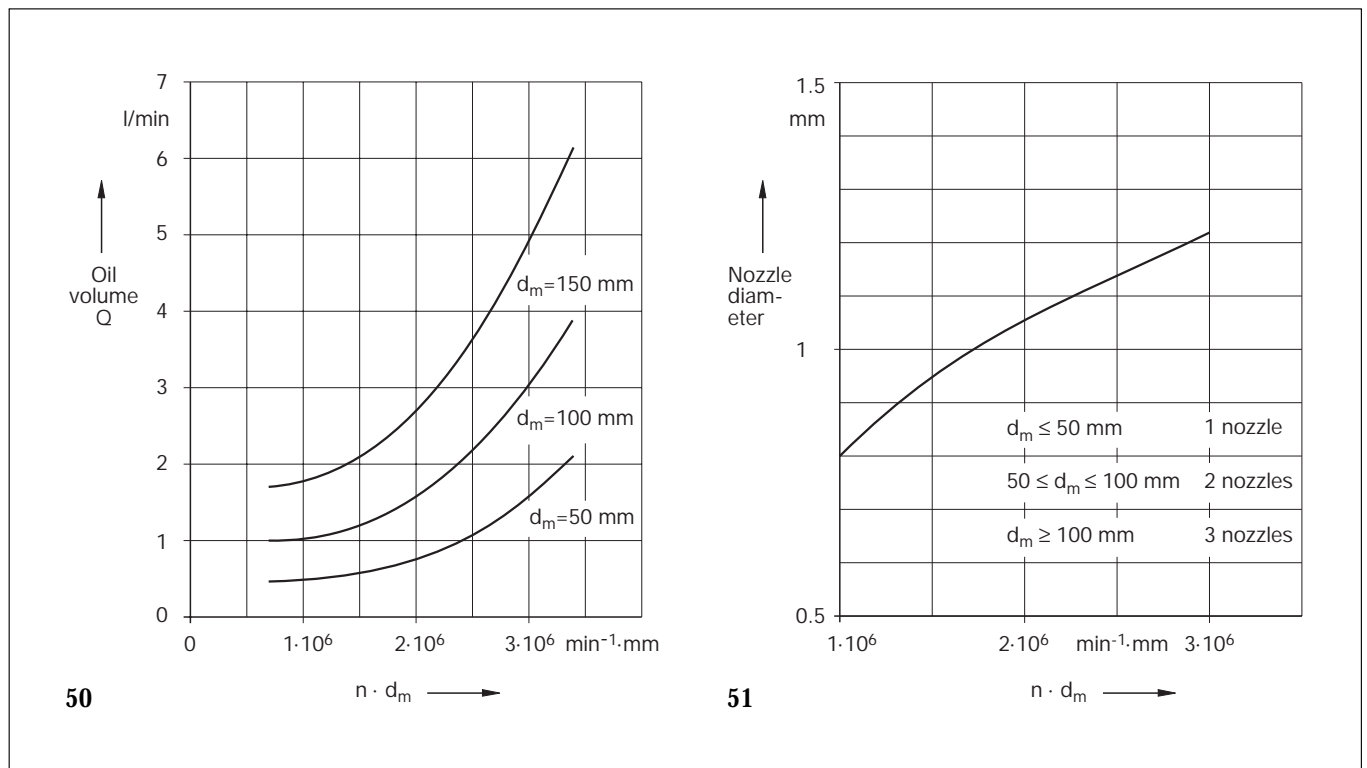

Lubricant Supply

Oil

from the bearing and a certain amount of oil is present. A combination of an oil sump with a circulation system increases the operational reliability, because, in the case of pump failure, the bearing continues to be supplied with oil from the sump for some time. At low temperatures, the oil flow rate can be reduced to the quantity required for lubrication until the oil has heated in the reservoir (fig. 49, curve a). This helps to simplify the circulating oil system (pump drive, oil return pipe).

If major oil quantities are used for lubrication, retention of the oil must be avoided by means of **discharge pipes** because retention would lead to substantial energy losses due to churning and friction especially at high circumferential velocities. The diameter of the discharge ducts

depends on the oil viscosity and the angle of inclination of the discharge pipes. For oils with an operating viscosity of up to $500 \text{ mm}^2/\text{s}$, the discharge diameter can be roughly calculated as follows:

$$d_a = (15 \dots 25) \cdot \sqrt{m} \quad [\text{mm}]$$

For dimensioning the discharge pipes more accurately for gradients from 1 to 5 % the following equation is used:

$$d_a = 11,7 \cdot \sqrt[4]{m \cdot \nu / G} \quad [\text{mm}]$$

where d_a [mm] is the inside diameter of the discharge pipe, m [l/m] is the oil

flow rate, ν [mm^2/s] is the operating viscosity, and G [%] is the inclination.

The amount of oil M in the oil reservoir depends on the flow rate m . As a rule, the fill of the reservoir should be circulated $z = 3$ to 8 times per hour.

$$M = m \cdot 60 / z \quad [l]$$

If the z value is low, foreign matter settles in the reservoir, the oil can cool down and does not deteriorate so quickly.

52: Pressure drop and jet velocity versus oil volume, operating viscosity and nozzle diameter

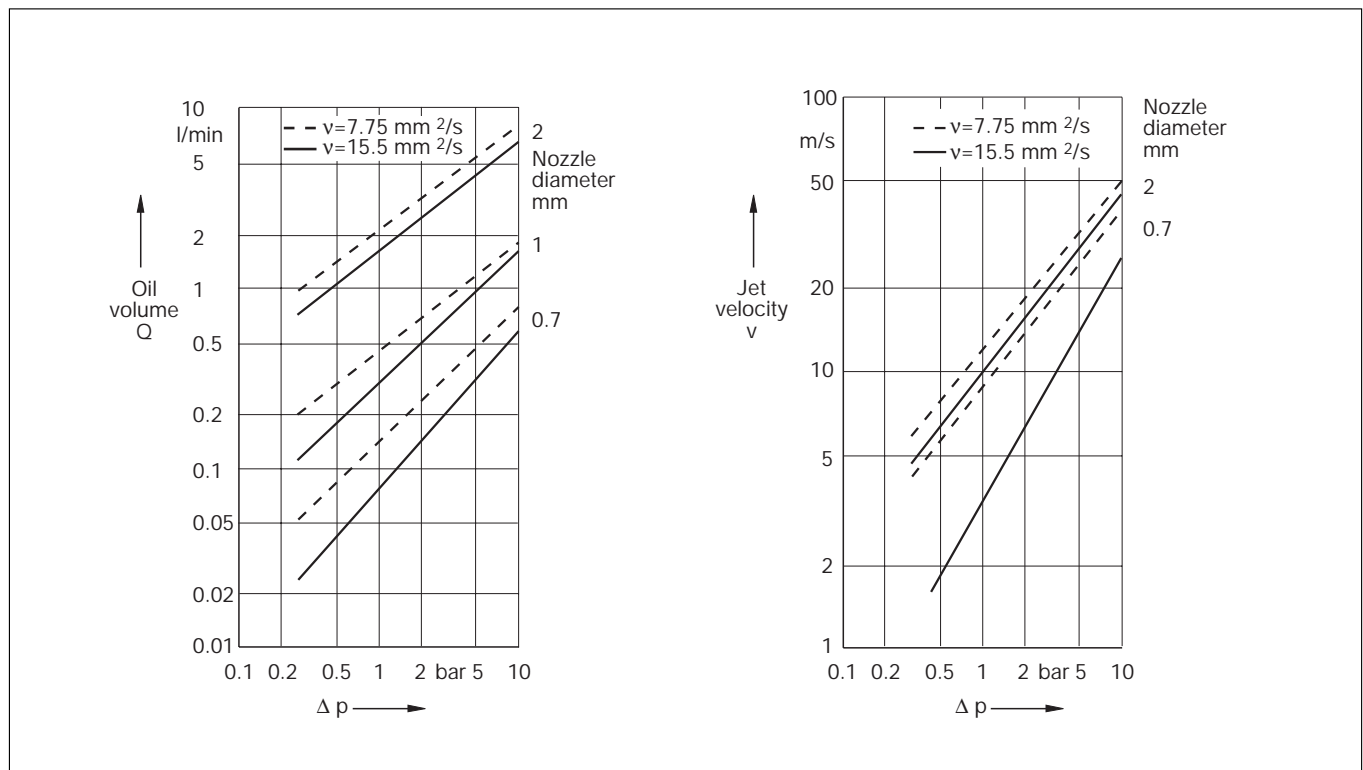

4.2.4 Throwaway Lubrication

The oil volume fed to the bearing can be reduced below the lower limit indicated in diagram 49, if a low bearing temperature is required without a large volume of oil. This, however, requires suitable bearing friction and heat dissipation conditions. In figs. 53 and 54 the change of friction moment and bearing temperature depending on the oil volume used for throwaway lubrication is illustrated by the example of a double-row cylindrical roller bearing. This example shows particularly well how sensitive to overlubrication double-row cylindrical roller bearings with lips on the outer ring are. More suitable are double-row cylindrical roller bearings with lips on the inner ring (NN30..) or single-row cylindrical roller bearings of series N10 and N19. The

state of minimum friction and minimum temperature, that is when full fluid film lubrication sets in, is already reached with an oil volume of 0.01 to 0.1 mm³/min. The bearing temperature rises up to an oil volume of 10⁴ mm³/min. Beyond that volume heat is dissipated from the bearing.

The oil quantity required for an adequate oil supply largely depends on the bearing type. Bearings where the direction of the oil flow coincides with the pumping direction of the bearing require a relatively large oil supply. Double-row bearings without conveying effect require an extremely small amount of oil if it is fed between the two rows of rolling elements. The rotating rolling elements prevent the oil from escaping.

Lubrication with very small amounts of oil requires that all contact areas in the bearing, especially the tribologically de-

manding sliding contact areas (lip and cage guiding surfaces) are adequately covered with oil. In the case of machine tools with ball bearings and cylindrical roller bearings, it is advantageous to feed oil directly to the bearings, and in the direction of conveyance of angular contact ball bearings. Diagramm 55 shows minimum oil quantities versus the bearing size, the contact angle (conveying effect) and the speed index for some bearing types. For bearings with a conveying effect, the oil volume should be increased as a function of speed as the minimum oil quantity required and the conveying effect increase with the speed.

For bearings with lip-roller face contact (e.g. tapered roller bearings), direct oil supply to the roller faces, opposite to the conveying direction, has proved to be suitable.

53: Friction moment versus oil volume with throwaway lubrication

54: Bearing temperature versus oil volume with throwaway lubrication

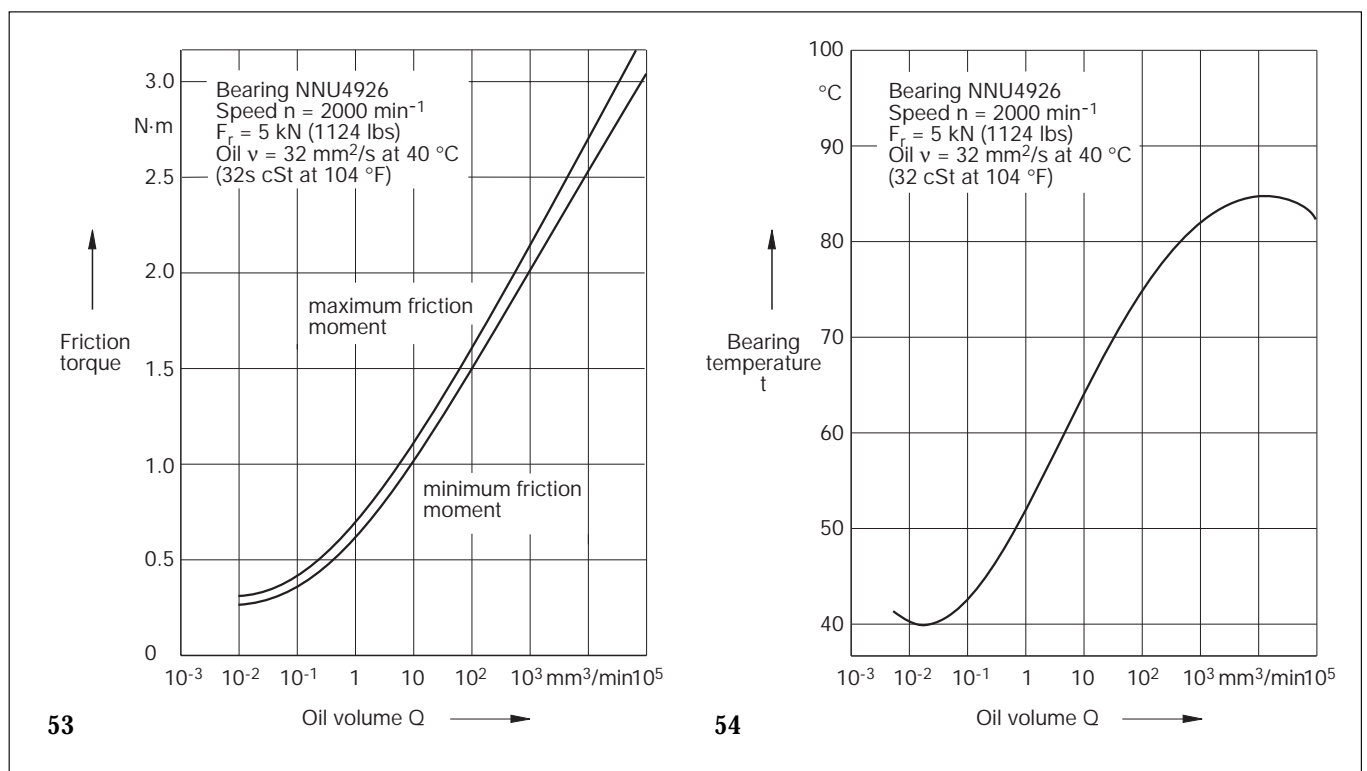

Lubricant Supply

Oil

The extremely small oil quantities require an assured supply of the oil-air mixture between cage and inner ring as well as extremely accurate mating parts. The oil should have a viscosity which corresponds to the viscosity ratio $\lambda = \nu/\nu_1 = 8$ bis 10 and contain suitable EP additives.

Continuous supply of a large oil quantity or the intermittent supply even of small quantities at high circumferential

velocities lead to a sharp rise in lubricant friction and a temperature difference between inner and outer rings of cylindrical roller bearings. This can result in detrimental radial preloading and eventually in the failure of bearings which have a small radial clearance (e.g. machine tool bearings).

Fig. 56 shows an example of the selection of the suitable oil volume for throwaway lubrication for double-row cylindrical roller bearings NNU4926. Line a

shows the minimum oil volume as a function of the speed index. Line b represents the maximum oil volume; beyond this line excessive radial preloading can occur. The diagram is based on the assumption of a continuous oil supply (oil-air lubrication) and average heat dissipation.

The point of intersection of lines a and b represents the maximum speed index for throwaway lubrication. The adequate

55: Oil volumes for throwaway lubrication

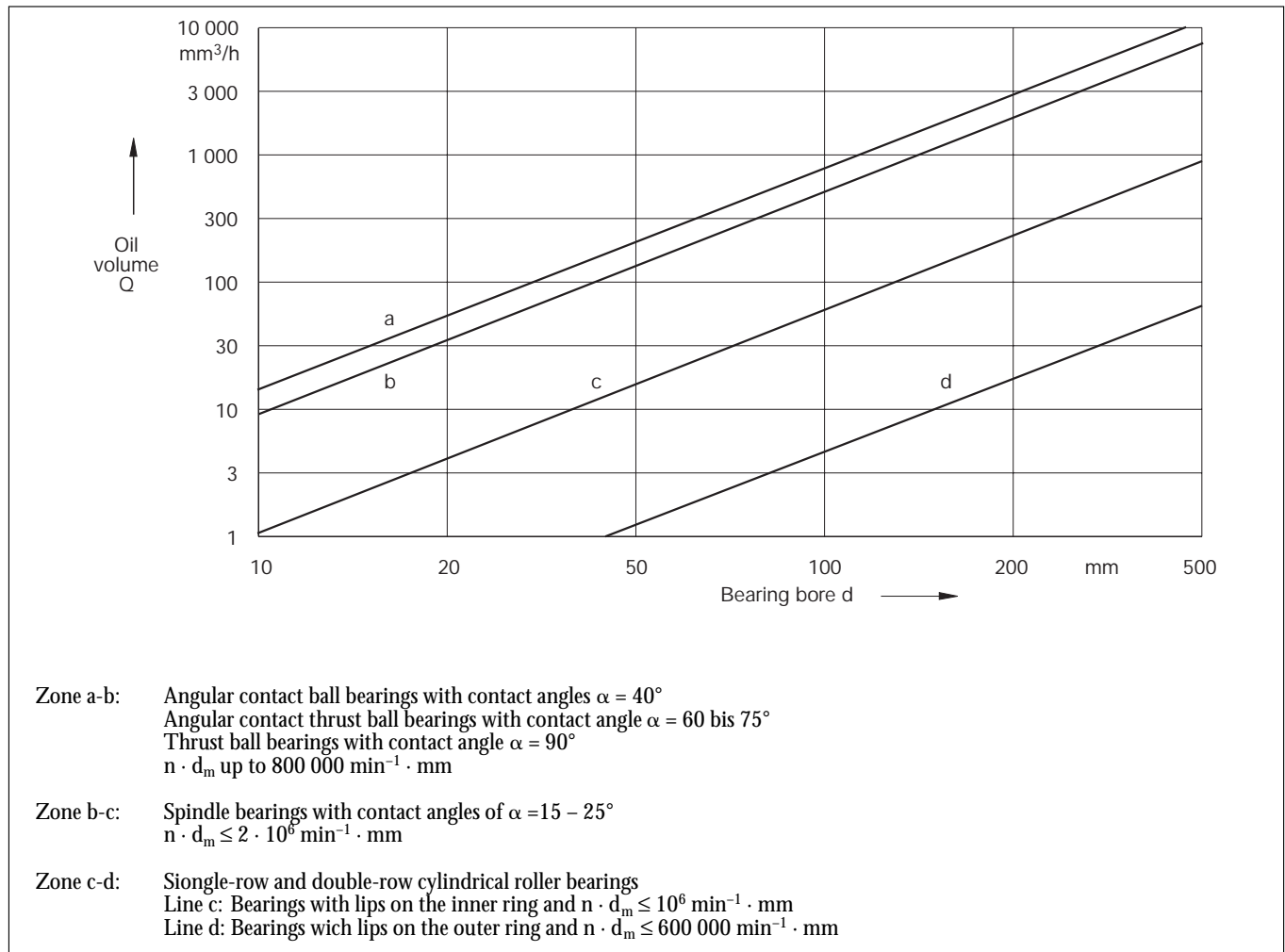

oil volume for double-row cylindrical roller bearings is shown by line d in diagram 55. Since the minimum and maximum oil volumes depend not only on the bearing but also on the oil type, the oil supply and heat dissipation it is not possible to furnish a general rule for determination of the speed index and the optimum small oil quantities. The viscosity of the oil selected should result in a viscosity ratio of $\kappa = 2$ to 3.

The oil-air lubrication system used for rolling mill bearings is usually combined with an oil sump and is not some kind of throwaway lubrication. The oil volume supplied adds to the oil sump and should be larger than $1,000 \text{ mm}^3/\text{h}$.

4.2.5 Examples of Oil Lubrication

Fig. 57: Larger housings with a correspondingly large amount of oil should

be provided with baffle plates forming compartments interconnected by holes. This prevents undue agitation of the whole oil sump especially at higher circumferential velocities and allows foreign matter to settle in the lateral compartments without being constantly stirred up.

56: Selection of oil volume for throwaway lubrication (example: double row cylindrical roller bearing NNU4926 (d = 130 mm, small radial clearance))

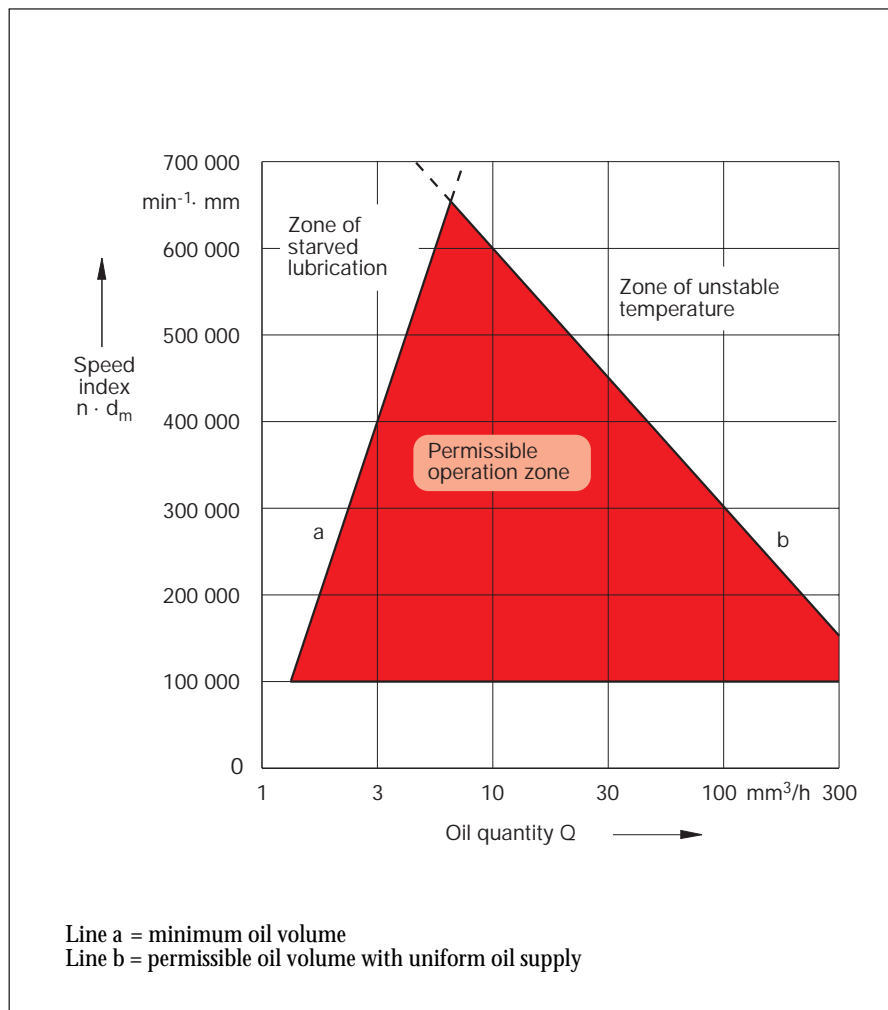

57: Bearing housing with baffle plates

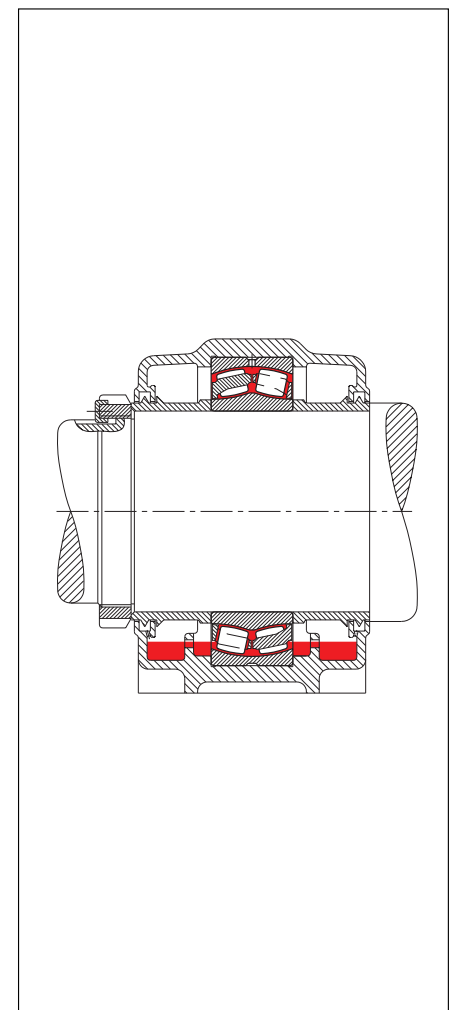

Lubricant Supply

Oil

Fig. 58: The bottom rollers of the spherical roller bearing are immersed in a small oil sump. Oil losses are compensated for by oil supplied from the larger oil sump below the spherical roller bearing. The ring oiler R has a diameter which is considerably larger than the shaft diameter; it dips into the lower oil sump which is not connected with the bearing. In operation, the ring oiler R turns on the shaft and feeds the oil to the bearing. Excess oil returns to the lower oil sump through bores A. Ring oilers can be used up to a speed index of $n \cdot d_m = 400\,000 \text{ min}^{-1} \cdot \text{mm}$. At higher speeds, the ring oiler shows heavy wear.

Fig. 59: Like all bearing types with an asymmetrical cross section, tapered roller bearings have a pumping effect. It depends heavily on the circumferential velocity of the bearing and can be utilized for circulating oil lubrication. The drain holes must be large enough to prevent oil retention at the bearing sides.

Fig. 60: Vertical high-speed spindles are sometimes designed with a tapered end, or a separate cone which rotates along with the spindle is fitted to them, the tapered end dipping into the oil reservoir. The oil is pumped up through the gap S into the circular groove from where it flows into an overhead dispenser. With this arrangement, relatively large oil quantities can be supplied, if the feed height is short and the oil viscosity is low.

Fig. 61: In gearboxes, transmissions etc., the oil thrown off the gears often provides for adequate bearing lubrication. However, the oil must actually enter the bearings under all operating conditions. In the example shown, the oil thrown off is collected in a pocket above the cylindrical roller bearing and fed to the bearing through grooves. A baffle plate is arranged beside the cylindrical roller bearing. It ensures that a certain amount of oil is always retained in the bearing and that the bearing is lubricated at start-up.

Figs. 62 and 63: With oil jet lubrication, the oil jet is forced between cage and inner ring. Oil drain ducts prevent oil

from being trapped at the bearing sides. If the bearings have a pumping effect, the oil is introduced at the smaller raceway

58: Oil circulation with ring oiler

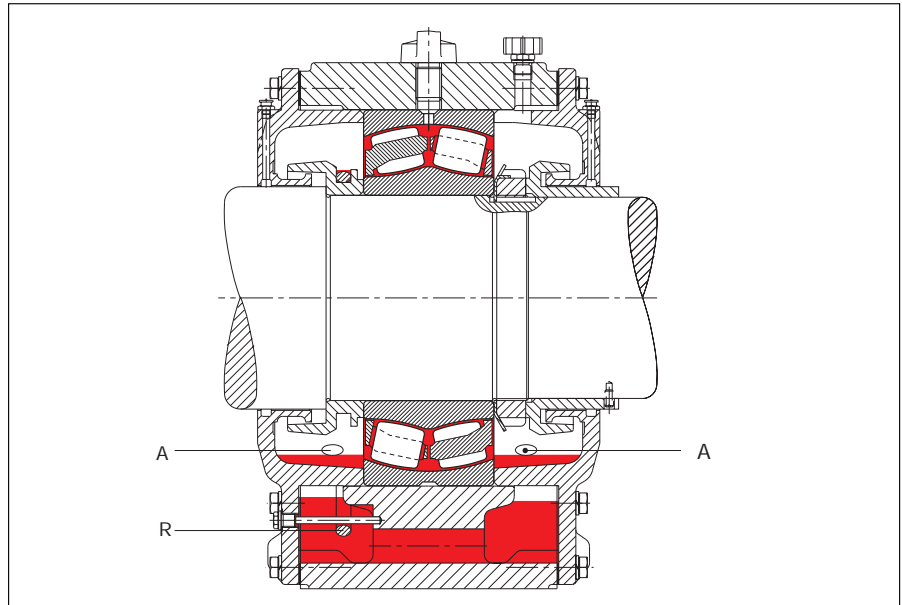

59: Oil circulation in bearings with conveying or pumping effect

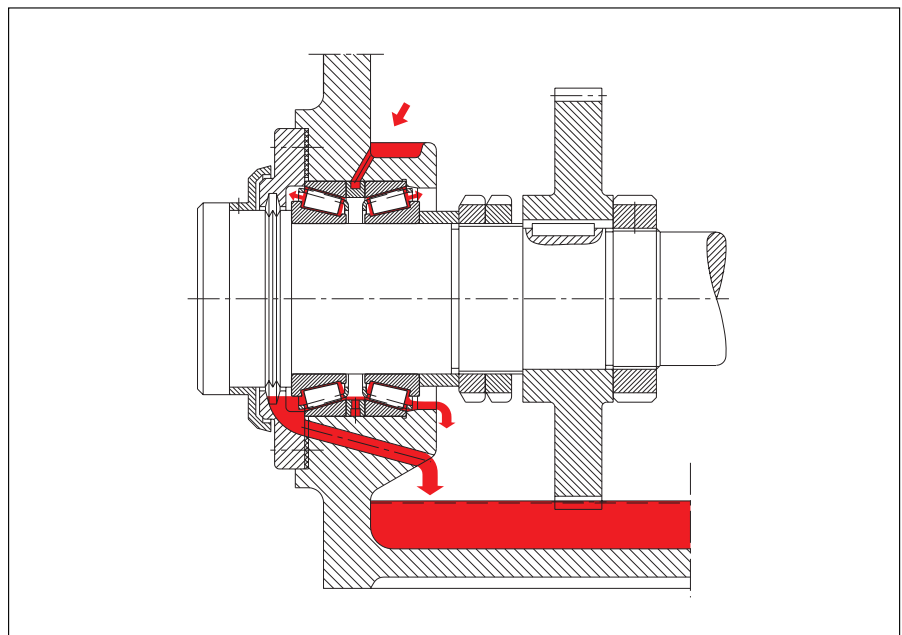

diameter. Oil is injected between the roller faces and the lip at the large race-way diameter of high-speed tapered roller

bearings. This counteracts starved lubrication between lip surfaces and roller faces.

60: Oil circulation by tapered spindle end

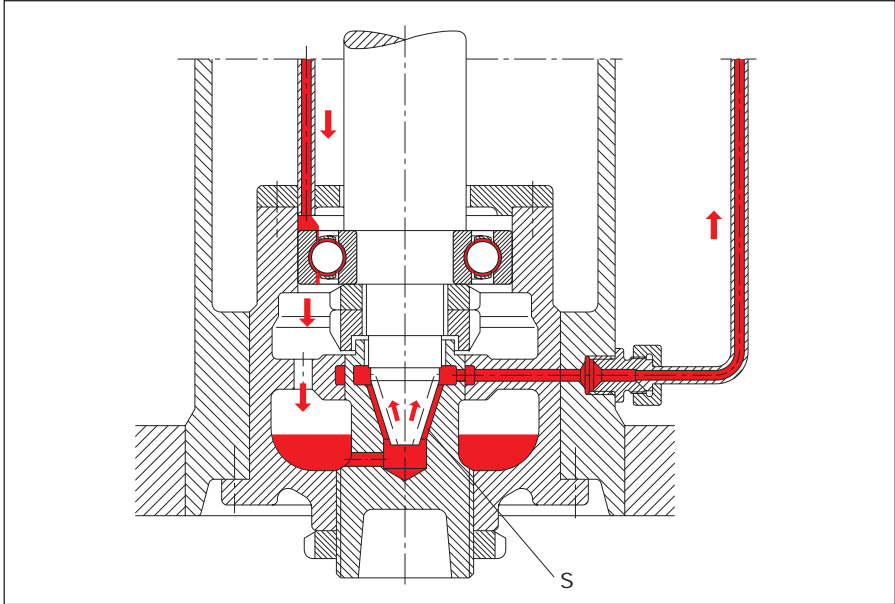

62: Oil jet lubrication with nozzles

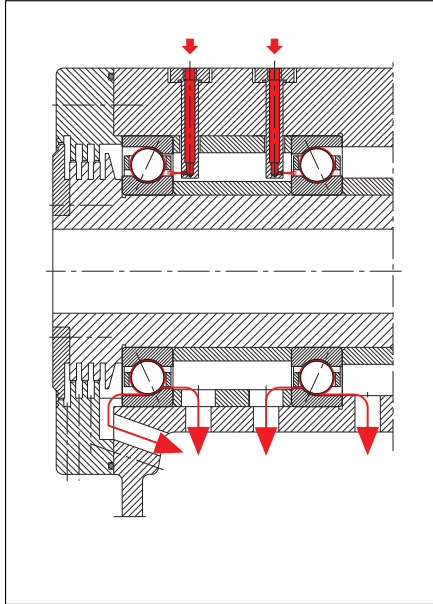

61: Oil thrown off is collected in a pocket and fed through grooves into the cylindrical roller bearing.

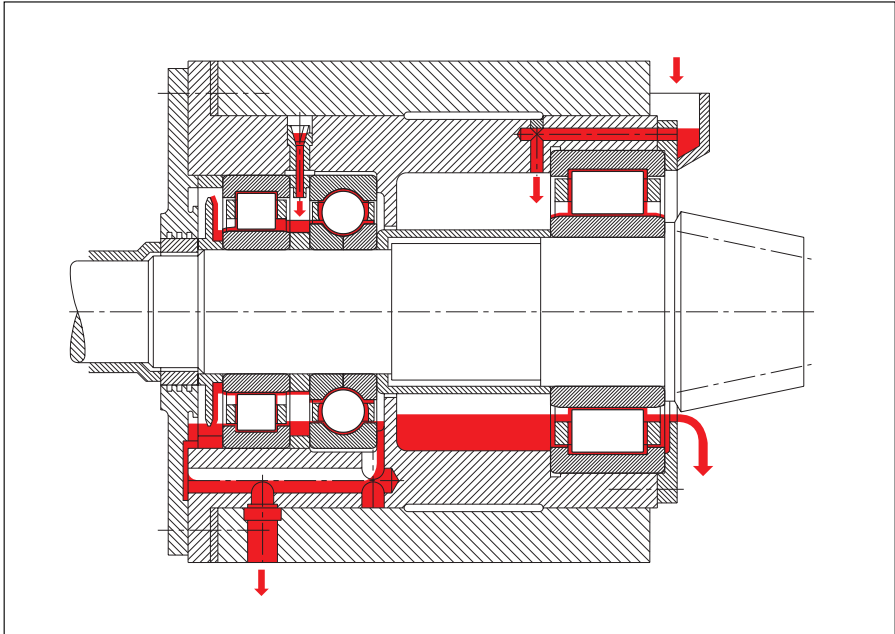

63: Oil jet lubrication: Oil supply at either side of a high-speed tapered roller bearing

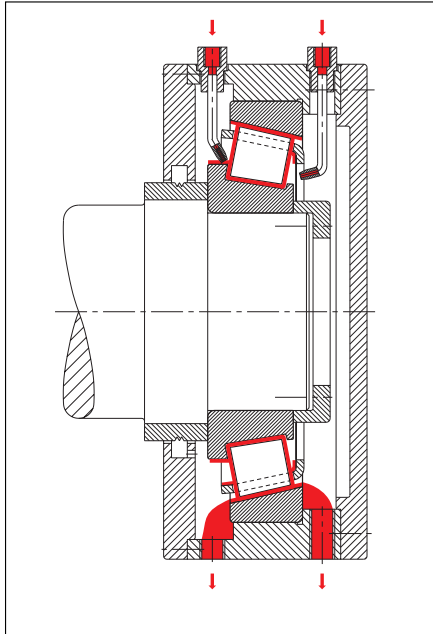

Lubricant Supply · Damage Due to Imperfect Lubrication

Dry Lubricante

4.3 Dry Lubricante Application

The most currently used dry lubricants are graphite and molybdenum disulphide. These lubricants are applied to the raceway surfaces in the form of loose powder, sliding lacquer or paste. When applying a powder coating, a brush, leather or cloth can be used; sliding lacquers are sprayed on the functional surfaces with a spray gun. The service life of many sliding lacquers can be increased by baking in the lacquer on the surfaces. Pastes are applied with a paint brush. Generally, the bearings are bonderized (manganese phosphate coating, phosphate coating) before

the dry lubricants are applied. The phosphate coating allows for better adhesion of dry lubricants, protects against corrosion and provides, to a certain extent, for emergency running properties. If high standards of protection against corrosion are required, the bearings are coated with a zinc-iron compound. Powders and lacquers only partially adhere to greasy bearings if at all. Perfect and uniform application is only possible at the bearing production plant before the individual components are assembled. Pastes can be applied prior to bearing mounting. Paste layers can be touched up or renewed. Overgreasing with pastes should be avoided.

An effective lubricant supply is provided by **transfer lubrication**. By filling the bearing with a solid lubricant compound which revolves along with the cage after solidifying, the rolling elements are regularly supplied with lubricant. This constant "relubrication" yields a long service life which far exceeds that reached by means of a sliding lacquer coating or a paste. The dry lubricant released by the rolling elements in the form of a powder escapes through the sealing gap. If this is an unwanted effect, a space can be provided between seal and pre seal where the rubbed-off particles will collect.

5 Damage Due to Imperfect Lubrication

More than 50% of all rolling bearing damage is due to imperfect lubrication. In numerous other cases which cannot be directly traced back to imperfect lubrication, it is one of the underlying causes of damage. Imperfect lubrication in the contact areas leads to wear, smearing, scoring, and seizure marks. In addition, fatigue damage (flaking) can occur. Sometimes, bearing overheating occurs if, in the case of starved lubrication or overlubrication, the bearing rings are heated to different temperatures due to unfavourable heat dissipation, resulting

in a reduction of radial clearance or even detrimental preload.

The main causes of the damage shown in fig. 64 are:

- unsuitable lubricant (oil of too low a viscosity, lack of additives, unsuitable additives, corrosive action of additives)
- starved lubrication in the contact areas
- contaminants in the lubricant (solid and liquid)
- alteration of lubricant properties
- overlubrication

Starved lubrication and overlubrication can be remedied by selecting a lubricant supply system adapted to the relevant application. Damage due to unsuitable lubricant or changes of the lubricant properties can be avoided by taking into

account all operating conditions in lubricant selection and by renewing lubricant in good time. Details have been given in the preceding chapters. The effects of contaminants in the lubricant and the resulting conclusions are described in this chapter.

5.1 Contaminants in the Lubricant

There are hardly any lubrication systems that are completely free from contaminants. The effects of contaminants on the life of a bearing are described in section 1.1.3. All lubricants contain a certain amount of contaminants stemming from their manufacture.

Damage Due to Imperfect Lubrication

64: Damage due to inadequate lubrication

Damage symptom	Cause	Notes
Noise	Starved lubrication	Local metal-to-metal contact; interrupted lubricating film without load transmitting and damping effect.
	Unsuitable lubricant	Lubricating film too thin, due to too low a viscosity of the oil or base oil of the grease. The structure of the grease thickener can be unsuitable. Particles can produce noise.
	Contaminants	Dirt particles disrupt the lubricating film and produce a noise.
Cage wear	Starved lubrication	Local metal-to-metal contact; interrupted lubricating film without load transmitting and damping effect.
	Unsuitable lubricant	Too low a viscosity of the oil or base oil, no boundary layer formation.
Wear on rolling elements, raceways, lip surfaces	Starved lubrication	Local metal-to-metal contact; interrupted lubricating film without load transmitting and damping effect. Tribocorrosion due to oscillating relative motions, slip marks.
	Unsuitable lubricant	Too low a viscosity of the oil or base oil. Lubricants without anti-wear or EP additives (high loads or high amount of sliding).
	Contaminants	Solid hard particles or liquid, corrosive media.
Fatigue	Starved lubrication	Local metal-to-metal contact, and high tangential stresses at the surface. Wear.
	Unsuitable lubricant	Too low a viscosity of the oil or base oil. Lubricant contains substances whose viscosity increases only slightly under pressure (e.g. water). Ineffective additives.
	Contaminants	Hard particles are rolled in, resulting in high local contact pressure. Corrosive media produce corrosion spots which are particularly fatigue promoting.
High bearing temperature, discoloured bearing parts, seizure marks (overheating)	Starved lubrication	Local metal-to-metal contact; interrupted lubricating film without load transmitting and damping effect.
	Unsuitable lubricant	High friction and temperature due to local metal-to-metal contact.
	Overlubrication	At medium or high rotational speed, high lubricant friction, especially in the case of sudden overlubrication.
Damaged lubricant (discolouration, solidification, loss of lubricity)	Starved lubrication	Operating temperature higher than the temperature permissible for the lubricant (formation of residues).
	Excessive operating time	Excessively long relubrication or lubricant renewal intervals.
	Contaminants, alteration of the lubricant	Foreign or wear particles in the bearing. Reaction between lubricant and bearing material.

Damage Due to Imperfect Lubrication

The minimum requirements for lubricants specified in DIN standards list, among others, limits for the permissible contamination at the time of lubricant supply. In most cases, contaminants enter the bearing on mounting due to insufficient cleaning of the machine components, oil pipelines etc., and during operation due to insufficient seals or openings in the lubrication unit (oil reservoir, pump). During maintenance, contaminants can also penetrate into the bearing, for example through dirt on the grease nipple and on the mouthpiece of the grease gun, during manual greasing, etc.

For assessing the detrimental effect of contaminants it is essential to know:

- the type and hardness of the foreign particles
- the concentration of the foreign particles in the lubricant
- the size of foreign particles

5.1.1 Solid Foreign particles

Solid foreign particles lead to running noise, wear and premature fatigue. Hard particles in rolling bearings cause abrasive wear, particularly in contact areas with a high rate of sliding friction, for example between the roller faces and the lip surfaces of tapered roller bearings or between the contact surfaces of raceway edges and rollers in cylindrical roller thrust bearings. Wear increases with the particle hardness and more or less proportionately with the concentration of the particles in the lubricant and the particle size. Wear even occurs with extremely small particles. Abrasive wear in rolling bearings is acceptable to a certain extent, the permissible amount of wear depending on the application. Cycling of larger particles (in the order of 0.1 mm) causes indentations in the raceways. Plastically deformed material is rolled out at the edges and only partly removed during subsequent cycling. Each subsequent load cycle causes higher stresses in the area of the indentation which result in a reduced fatigue life. The greater the hardness of the cycled particles (e.g. file dust,

grinding chips, mould sand, corundum) and the smaller the bearings, the shorter the life, see fig. 65.

5.1.2 How to Reduce the Concentration of Foreign Particles

The following precautions have to be taken:

- thorough cleaning of the bearing mating parts
- cleanliness in mounting, operation and maintenance
- with oil lubrication, filtering the oil (see section 1.1.3)
- with grease lubrication, sufficiently short grease renewal intervals

5.1.3 Oil filters

Modern filtering elements retain a wide spectrum of particles every time the oil volume passes through them. Therefore, test methods were standardized which take into account this particle spectrum and the multipass effect. The filtration ratio β_x indicates the ability of the filter to retain particles of certain sizes. The β_x value, measured in accordance with ISO 4572, represents the ratio of all particles $> x \mu\text{m}$ before and after filtering, fig. 66. For instance, $\beta_{12} = 75$ means that of 75 dirt particles which are $12 \mu\text{m}$ in size only one particle passes through the filter.

The effects of solid contaminants on the attainable life of rolling bearings is described in more detail in section 1.1.3.

65: Life reduction due to solid contaminants -- demonstrated by the example of a 7205B angular contact ball bearing

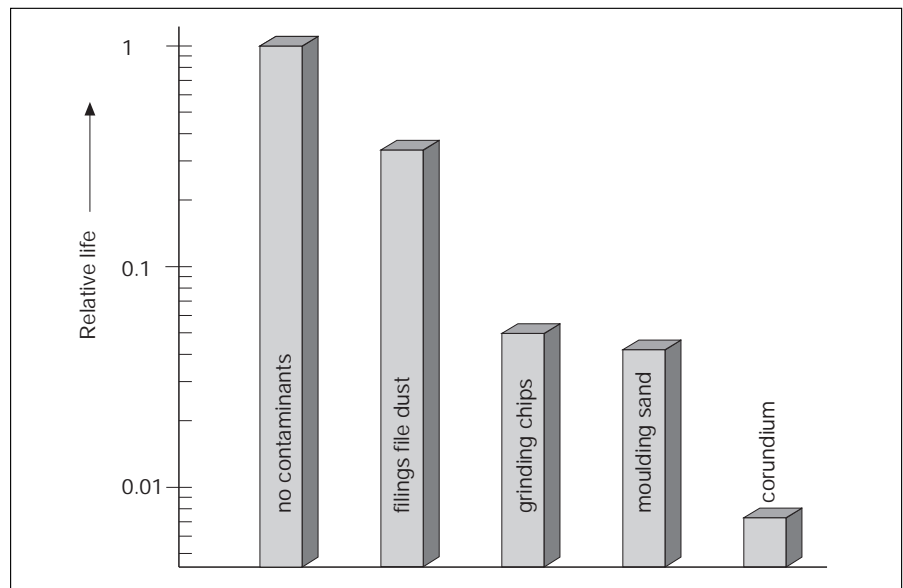

5.1.4 Liquid Contaminants

The main liquid contaminants in lubricants are water or aggressive fluids, such as acids, bases or solvents. Water may be free, dispersed or dissolved in oils. With free water in oil, visible by the oil discolouration (white-grey), there is the risk of corrosion. This risk is accelerated by hydrolysis of the sulphur bonded with the lubricant. Dispersed water in form of a water-in-oil emulsion affects the lubricating condition significantly. Experience has shown that the fatigue life of bearings lubricated with these aqueous oils decreases considerably. It can be reduced to a very small percentage of the normal fatigue life. Water in greases causes struc-

tural changes depending on the thickener. As is the case with water-in-oil emulsions, the fatigue life is reduced. With contamination by water, the grease renewal intervals must be shortened depending on the amount of water. Aggressive agents (acids, bases), solvent, etc. can drastically alter the chemo-physical characteristics and eventually deteriorate the lubricant. Information and recommendations on the compatibility of lubricants with these agents, which are given by the lubricant manufacturers, must be observed. On areas in the bearings which are not protected by the lubricant, corrosion develops and finally destroys the surface, depending on the aggressiveness of the contaminants.

5.2 Cleaning Contaminated Rolling Bearings

For cleaning rolling bearings, naphta, petroleum, ethanol, dewatering fluids, aqueous neutral or alkaline cleansing agents can be used. Petroleum, naphta, ethanol and dewatering fluids are inflammable, and alkaline agents are caustic. When washing out bearings, paint brushes or brushes, or lint-free cloth should be used. Immediately after washing and evaporation of the solvent, which should be as fresh as possible, the bearings must be preserved in order to avoid corrosion. The compatibility of the preservative with the subsequently used lubricant has to be ensured. If gummed oil and grease residues stick to a bearing, it should be mechanically precleaned and soaked for an extended period of time in an aqueous, strong alkaline cleansing agent.

66: Filtration ratio β_x

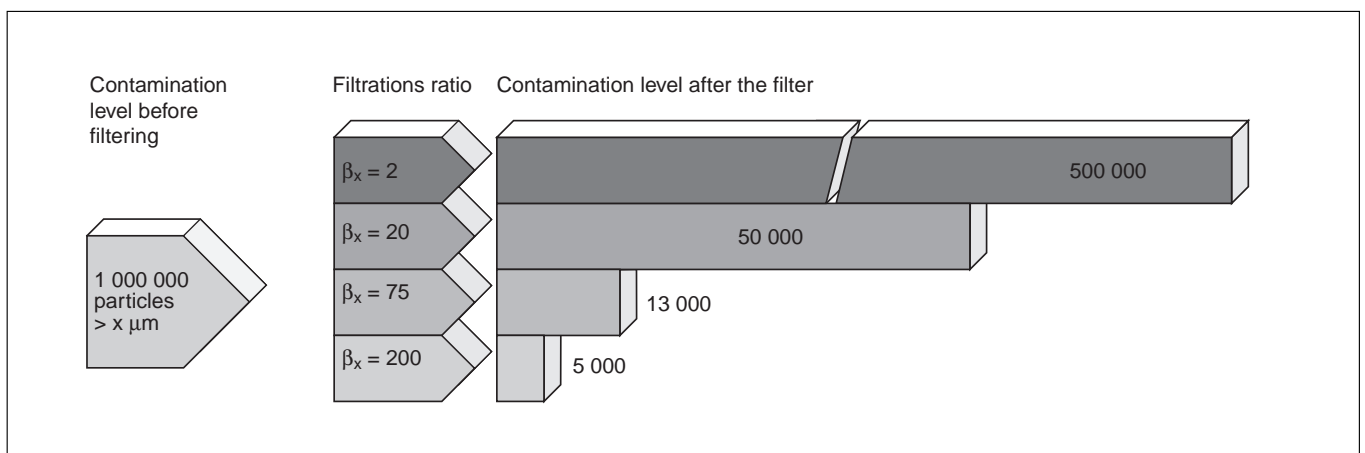

Damage Due to Imperfect Lubrication

5.3 Prevention and Diagnosis of Incipient Bearing Damage by Monitoring

Bearing failures due to imperfect lubrication can be avoided by monitoring the bearing:

- by measuring vibrations, wear and temperature
- by monitoring the bearing lubrication, analysing lubricant samples and checking the lubricant supply system.

Temperature measurements are a very reliable and relatively easy method of

detecting lubricant-related damage. The temperature behaviour is normal if the bearing reaches steady-state temperature in stationary operation. Starved lubrication is indicated by a sudden temperature increase. An erratic temperature curve whose peaks tend to increase indicates a general impairment of the lubricating condition, e.g. when the grease service life reaches its end.

Temperature measurements are not suitable for detecting fatigue damage early. Such locally restricted damage is best detected by means of vibration measurements.

Bearing damage which involves wear can be spotted by means of nonintermittent or intermittent lubricant analyses.

Monitoring the bearing lubrication also provides important data for maintenance. Table 67 lists the common methods for bearing monitoring and the type of damage they can detect. Table 68 gives information on lubrication monitoring.

67: Bearing monitoring

Measurable variables	Measuring method, measuring devices	Detectable types of damage
Oscillations Vibrations Airborne sound Structure-borne sound	Search for source of trouble Frequency analysis (amplitude, velocity, acceleration) shock pulse measurements	Fatigue Fracture Flutes Scores
Wear	Monitoring of abrasion by measuring the displacement of the bearing components relative to one another (inductive, capacitive, eddy current measuring methods) Radionuclide measurement Lubricant analysis	Wear of bearing components
Temperature	Thermometer Thermocouple Resistance thermometer Thermoplates Comparison of measured values	Overheating Dry running Seizure

68: >Lubrication monitoring

Monitored variables	Method	Detectable and avoidable
Lubricant	Analysis (content of water, solid foreign particles, neutralization number, saponification number)	Fatigue Wear Corrosion Deteriorated or unsuitable lubricant
Lubrication system	Oil pressure Oil level Oil flow rate Oil temperature	Overheating Wear

6 Definition of Tribological Terms

Additives

Oil soluble substances added to mineral oils or mineral oil products. By chemical and/or physical action, they change or improve the lubricant properties (oxidation stability, EP properties, foaming, viscosity-temperature behaviour, setting point, flow properties, etc.).

Additive-treated Lubricants

Lubricating oils or greases which contain one or several additives to improve special properties. -> Additives.

Adhesive Oils

Tough and sticky, generally bituminous lubricants with a high viscosity; as a rule, must be used in a diluted form.

Ageing

-> Deterioration

Aluminium Complex Soap Base Greases

Their resistance to water is good; when doped with EP additives, they have a high load carrying capacity. Depending on their base oil, they can be used for temperatures up to approximately 160 °C.

Aluminium Soap Base Greases

Lubricating greases consisting of aluminium soap and mineral oils. They are mainly used in gearboxes for gear lubrication.

Anti-Oxidants

Additives which considerably retard lubricating oil deterioration.

Anti-Stick-Slip Additives

Additives which are added to lubricants to prevent stick-slip operation, e.g. carriage tracks and guideways in machine tools.

Antiwear Additives

Additives to reduce wear in the mixed friction range. Distinction is made between

- mild additives, e.g. fatty acids, fatty oils
- EP additives, e.g. sulphuric, phosphorous and zinc compounds,
- dry lubricants, e.g. graphite, molybdenum disulphide.

Arcanol

FAG rolling bearing greases are field-proven lubricating greases. Their scopes of application were determined by FAG by means of the latest test methods (test rigs FE8 and FE9) under a large variety of operating conditions and with rolling bearings of all types. The eight Arcanol greases listed in the table on page 58 cover almost all demands on the lubrication of rolling bearings.

Aromatics

Unsaturate hydrocarbons with a molecular ring structure (benzene, toluol, naphthalene). Aromatics have poor viscosity-temperature properties and affect the oxidation stability of lubricants.

Ash Content

refers to the incombustible residues of a lubricant. The ash can be of different origins: it can stem from additives dissolved in the oil; graphite and molybdenum disulphide, soaps and other grease thickeners are ash products. Fresh, straight mineral oil raffinates must be completely ash free. Used oils also contain insoluble metal soaps produced during operation, incombustible residues of contaminants, e.g. wear particles from bearing components and seals, etc. Sometimes, incipient bearing damage can be diagnosed from the ash content.



Glossary of Terms

Arcanol rolling bearing greases · Chemo-physical data and directions for use

Arcanol	Thickener Base oil	Base oil viscosity at 40 °C mm ² /s	Consistency NLGI-class DIN 51818	Temperature range °C	Main characteristics Typical applications
L12V	Calcium/ polyurea PAO	130	2	-40...+160	Special grease for high temperatures Couplings, electric machines (motors, generators)
L71V	Lithium soap Mineral oil	ISO VG 100	3	-30...+140	Standard grease for bearings with O.D.s > 62 mm large electric motors, wheel bearings for motor vehicles, ventilators
L74V	Special soap Synthetic oil	ISO VG 22	2	-40...+100	Special grease for high speeds and low temperatures Machine tools, spindle bearings, instruments
L78V	Lithium soap Mineral oil	ISO VG 100	2	-30...+140	Standard grease for bearings with O.D.s ≤ 62 mm Small electric motors, agricultural and construction machinery, household appliances
L79V	PTFE Synthetic oil	400	2	-40...+260	Special grease for extremely high temperatures and chemically aggressive environment Track rollers in bakery machines, piston pins in compressors, kiln trucks, chemical plants
L135V	Lithium soap with EP additives Mineral oil + Ester	85	2	-40...+150	Special grease for high loads, high speeds, high temperatures Rolling mills, construction machinery, motor vehicles, rail vehicles, spinning and grinding spindles
L166V	Lithium soap with EP additives Mineral oil	170	3	-30...+150	Special grease for high temperatures, high loads, oscillating movements Rotor blade adjusting mechanisms for wind power stations, packaging machinery
L186V	Lithium soap with EP additives Mineral oil	ISO VG 460	2	-20...+140	Special grease for extremely high loads, medium speeds, medium temperatures Heavily stressed mining machinery, construction machinery, machines with oscillating movements
L195V	Polyurea with EP additives Synthetic oil	ISO VG 460	2	-35...+180	Special grease for high temperatures, high loads Continuous casting plants
L215V	Lithium-/ Calcium soap with EP additives Mineral oil	ISO VG 220	2	-20...+140	Special grease for high loads, wide speed range, high humidity Rolling mill bearings, rail vehicles
L223V	Lithium-/ Calcium soap with EP additives Mineral oil	ISO VG 1000	2	-20...+140	Special grease for extremely high loads, low speeds Heavily stressed mining machinery, construction machinery, particularly for impact loads and large bearings

ASTM

Abbreviation for American Society for Testing Materials. Institution which draws up, among other things, the U.S. mineral oil standards.

ATF

Abbreviation for Automatic Transmission Fluid. Special lubricants adapted to the requirements in automatic transmissions.

Barium Complex Soap Base Greases

Lubricating greases consisting of barium complex soaps and mineral oils or synthetic oils. They are water-repellent, retain their consistency, and form a lubricating film with a high load carrying capacity.

Base Oil

is the oil contained in a grease. The amount of oil varies with the type of thickener and the grease application. The penetration number and the frictional behaviour of the grease vary with the amount of base oil and its viscosity.

Bentonites

Minerals (e.g. aluminium silicates) which are used for the production of thermally stable greases with good low-temperature properties.

Bleeding

The oil contained in the lubricating grease separates from the thickener. This can be caused, e.g. by low resistance to working and/or low temperature stability of the grease.

Brightstock

Refined oil of high viscosity, a product of vacuum distillation. Compound for lubricating oils, improves the lubricity.

Calcium Soap Base Greases

Calcium soap base greases are completely water-repellent and are therefore excellent sealants against the ingress of water. However, since their corrosion protection is limited, they must contain anti-corrosion additives. Doped calcium soap base greases are appropriate even in applications where they are exposed to large amounts of water. Temperature limits of normal calcium soap base greases: approx. -20°C to $+50^{\circ}\text{C}$.

Centipoise (cP)

Former unit for the dynamic viscosity.
1 cP = 1 mPa s

Centistoke (cSt)

Former unit for the kinematic viscosity.
1 cSt = 1 mm²/s

Characteristics

The following are the characteristics of lubricating oils: flash point, density, nominal viscosity, setting point and additive data.

Lubricating greases are defined by: type of thickener, type and viscosity of base oil, drop point, worked penetration and, where present, additives.

Circulating Effect

If grease is carried along by rotating parts the rotation causes lumps of grease to be pulled between rolling elements and raceways with a corresponding increase in friction due to grease working. High-speed applications therefore require greases which are not likely to be carried along. The circulating effect depends on the type of thickener, penetration, temperature and the bearing type. Especially sodium soap base greases tend to participate in the circulating movement.

Colour of Oils

Spent oils are often judged by their colour. However, caution should be exer-

cised in using this criterion because even fresh oil can be more or less dark. Whether the discolouration is due to oxidation can only be confirmed by comparing it with a fresh sample of the same oil type. Contamination by dust and soot, however small the quantity, may also be a cause of discolouration.

Complex Greases

Besides metal soaps of high-molecular fatty acids, complex soap base greases contain metal salts of low-molecular organic acids. These salts and the soap form a complex compound which outperforms conventional greases as far as thermal stability, water resistance, anti-corrosive action and load carrying capacity are concerned.

Consistency

is defined as the resistance of a grease to being deformed. -> Penetration.

Copper Corrosion Test

Method for determining active sulphur in mineral oils (DIN 51 759) and in greases (DIN 51811).

Corrosion Inhibiting Greases, Corrosion Inhibiting Oils

They protect corrodible metal surfaces against moisture and atmospheric oxygen.

Demulsifying Ability

Ability of oils to separate from oil-water mixtures.

Density

The density r of mineral oil products is expressed in g/cm³ at 15 °C. The density of mineral lubricating oils $\rho = 0.9 \text{ g/cm}^3$. It depends on the chemical composition of the oil. For oils of the same origin it increases with viscosity and decreases with increasing degree of refining. Density in itself is no criterion of quality.

Glossary of Terms

Detergents

Additives which emulsify oxidation products, keep them in suspension, and prevent them from settling on surfaces to be lubricated.

Deterioration

is the undesirable chemical alteration of mineral and synthetic products (e.g. lubricants, fuels) during operation and storage; triggered by reactions with oxygen (formation of peroxides, hydrocarbon radicals); heat, light and catalytic influences of metals and other contaminants accelerate oxidation. Formation of acids and sludge.

-> Anti-Oxidants (AO) retard the deterioration process.

Dispersants

Additives in lubricating oils which hold fine dirt particles in suspension until they are filtered out or removed when the oil is changed.

Dispersion Lubrication

Method of applying the lubricant. The rolling bearing is dipped into the dispersion bath (dispersing agent and grease). After the dispersing agent has evaporated, a 1 to 100 µm thick lubricant layer remains on the bearing surfaces. Advantage: minimum friction. Drawback: reduced grease service life.

Distillates

Hydrocarbon compounds obtained from crude oil distillation.

Drop Point

Temperature at which a grease sample, when heated under standard test conditions, passes into a liquid state, flows through the opening of a grease cup and drops to the bottom of the test tube. Grease: DIN ISO 2176.

Dry Lubricants

Substances, such as graphite and molybdenum disulphide, suspended in oils and greases or applied directly.

Dynamic Viscosity

-> Viscosity.

Emcor Method

Testing of corrosion preventing properties of rolling bearing greases according to DIN 51 802.

Emulsibility

Tendency of an oil to emulsify with water.

Emulsifiers

Additives which help to form an emulsion.

Emulsion

Mixture of insoluble substances, usually mineral oils with water, which is activated by emulsifiers.

Elastic Behaviour of Lubricating Greases

The elastic properties of lubricating greases indicate the suitability of a grease for centralized lubrication systems (DIN 51 816T2).

EP Lubricants

Extreme pressure lubricants. Oils or greases which contain EP additives against wear.

Esters (Synthetic Lubricating Oils)

Compounds of acids and alcohols with water eliminated. Esters of higher alcohols with divalent fatty acids form the so-called diester oils (synthetic lubricating oils). Esters of polyhydric alcohols and different organic acids are particularly heat stable.

Evaporation Loss

Lubricating oil losses occurring at increased temperatures due to evaporation. It can lead to an increase in oil consumption and also to an alteration of the oil properties.

Extreme-Pressure Lubricants

-> EP lubricants.

Fire Point

Fire point is the minimum temperature under a certain pressure at which a uniformly heated fluid gives off sufficient vapour to burn continuously for at least five seconds: DIN ISO 2592.

Flash Point

Flash point is the minimum temperature to which, under specified test conditions, an oil must be heated for sufficient vapour to be given off to form an inflammable mixture with air. The flash point is one of the characteristics of oils; it is not a criterion for their quality.

Flow Pressure

Pressure required to press grease in a continuous stream from a nozzle. It is a measure of the consistency and fluidity of a grease. It is determined according to DIN 51 805 (in accordance with DIN 51 825 used for determining the lower operating temperature).

Foaming

Foaming in mineral oils should be avoided. Foaming promotes deterioration of the oil. Excessive foaming can lead to oil losses.

Four Ball Test Rig

Machine for lubricant testing (DIN 51 350). Four balls are arranged in a pyramid shape, with the upper ball rotating. The load applied can be increased until welding occurs between the balls (welding load). The load, expressed in N,

is the four ball welding load. The diameter of the weld scar on the three stationary balls measured after one hour of testing is the four ball wear value which is used for wear evaluation. Suitable for the identification testing of lubricants.

Gear Greases

Gear greases are usually sodium soap based, stringy, soft to semifluid greases (NLGI 0 and 00) for gears and gear motors. Some greases are treated with EP additives.

Gear Oils

Lubricating oils for all kinds of gears in accordance with DIN 51 509, 51 51711/12/13 (Lubricating Oils C, CL, CLP).

Gel Greases

Gel greases contain an anorganic-organic thickener made up of finely dispersed solid particles; the porous surface of these particles tends to absorb oil. Gel greases are suitable for a wide temperature range and are water resistant. Caution is recommended at high speeds and loads.

Grease Service Life

The grease service life is the period from start-up until the failure of a bearing as a result of lubrication breakdown. The grease service life is determined by the

- amount of grease,
- grease type (thickener, base oil, additives),
- bearing type and size,
- type and amount of loading,
- speed index,
- bearing temperature.

Grease Service Life Curve, F_{10}

The F_{10} value represents the service life of a certain grease and applies to a failure probability of 10 %. The grease service life F_{10} is determined in laboratory tests, e.g. on the FAG rolling bearing grease test rig FE9.

HD Oils

Heavy-duty oils are additive-treated engine oils particularly adapted to the rugged conditions in internal combustion engines.

High-Temperature Greases

Lithium soap base greases can be used at steady-state temperatures of up to 130 °C and polyurea greases up to 200 °C. Special synthetic greases can be used up to 270 °C.

Homogenizing

Final step in grease production. In order to obtain a uniform structure and fine dispersion of the thickener, the grease is thoroughly worked in a special machine where it is subjected to a great shearing force.

Hydraulic Fluids

Pressure fluids for hydraulic load transmission and control. Fire-resistant hydraulic fluids -> page 32.

Hydraulic Oils

Non-ageing, thin-bodied, non-foaming, highly refined hydraulic fluids produced from mineral oil, with a low setting point, for use in hydraulic systems.

Hypoid Oils

High-pressure oils with EP additives for hypoid gears, mainly for axle drive systems in motor vehicles.

Inhibitors

Additives which retard certain reactions of a lubricant. They are used preferably as a protection against deterioration and corrosion in lubricants.

Kinematic Viscosity

-> Viscosity.

Lithium Soap Base Greases

have definite performance merits in terms of water resistance and width of temperature range. Frequently, they incorporate oxidation inhibitors, corrosion inhibitors and EP additives. Due to their favourable properties, lithium soap base greases are widely used as rolling bearing greases. Standard lithium soap base greases can be used at temperatures ranging from -35 to +130 °C.

Low-Temperature Properties

-> Setting point and flow pressure.

Lubricant Additives

-> Additives.

Lubricant Analysis Data

The analysed data of lubricants are: density, flash point, viscosity, setting point, drop point, penetration, neutralization number, saponification number. These are the physical and chemical properties of lubricants and indicate - within certain limits - the fields of application of the lubricants. -> Specifications.

Lubricating Greases

Greases are consistent mixtures of thickeners and oils. The following grease types are distinguished:

- Metal soap base greases consisting of metal soaps as thickeners and lubricating oils,
- Non-soap greases comprising inorganic gelling agents or organic thickeners and oils,
- Synthetic greases consisting of organic or inorganic thickeners and synthetic oils. -> Table 27.

Lubricating Oils B

Dark, bituminous mineral oils with good adhesive properties: DIN 51513.

Lubricating Oils C, CL, CLP

Gear oils for circulation lubrication: DIN 51 517T1/T2/T3.

Glossary of Terms

Lubricating Oils CG

Slideway oils.

Lubricating Oils K

Refrigeration machine oils: DIN 51503.

Lubricating Oils N

Standard lubricating oils: DIN 51501.

Lubricating Oils T

Steam turbine lubricating and control oils: DIN 51 515T1.

Lubricating Oils V

Air compressor oils: DIN 51506.

Lubricating Oils Z

Steam cylinder oils: DIN 51 510.

Lubrication Interval

The lubrication interval corresponds to the minimum grease service life F_{10} of standard greases in accordance with DIN 51 825. The lubrication interval is entered as a function of $k_f \cdot n \cdot d_m$, valid for 70 °C, see diagram "Lubricating intervals" in fig. 33. This value is assumed if the grease service life F_{10} of the grease used is not known. If the capacity of a grease is to be fully utilized, the grease service life F_{10} , determined in tests under field-like conditions, has to be assumed, or one orients oneself by experimental values. Influences which reduce the lubrication interval are taken into account by reduction factors.

Mechano-Dynamic Lubricant Testing

The rolling bearing greases are tested under field-like operating and environmental conditions. The lubricant is analysed by the behaviour of test specimen and lubricant during testing and their condition after the test. Test rigs using single bearing components as test specimens give results which can be applied to

FAG test rig FE9

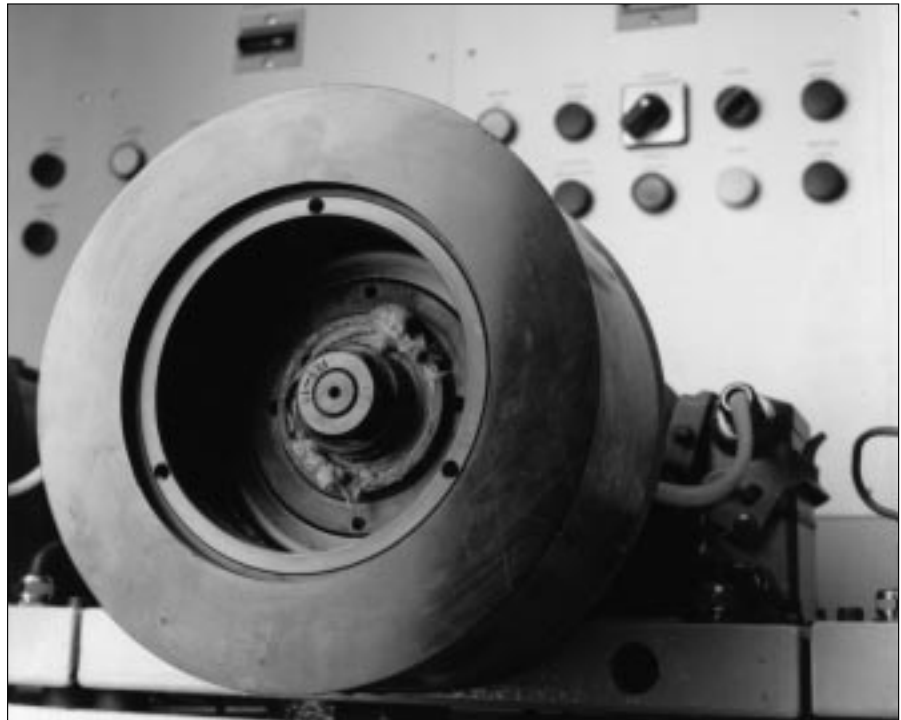

FAG test rig FE8

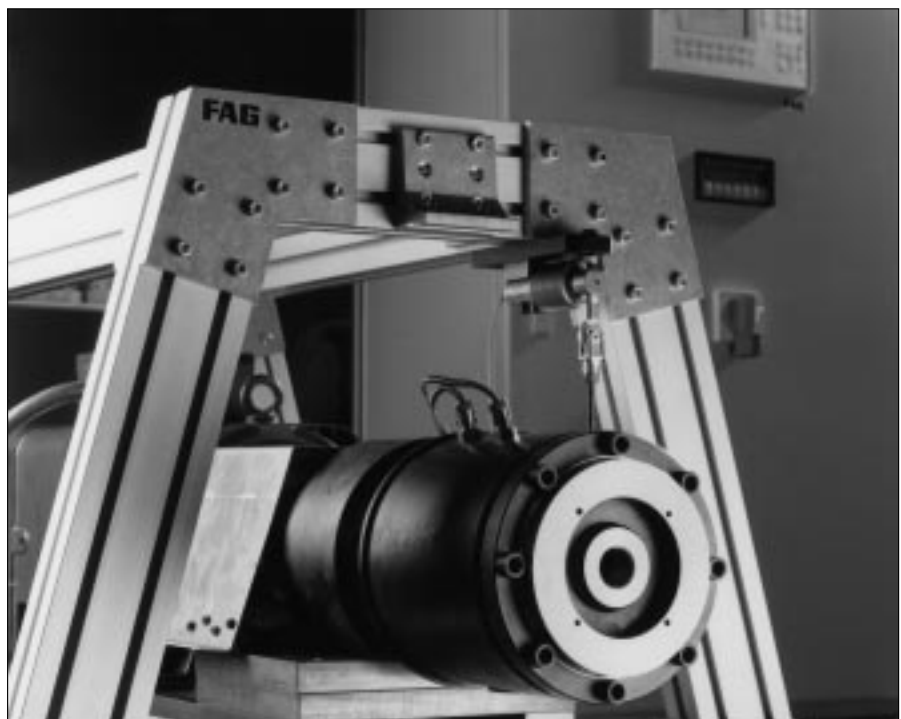

complete rolling bearings only to a limited extent. Therefore, test rigs are preferred in which rolling bearings are used as test specimens.

The FAG rolling bearing grease test rig FE9, which is in accordance with DIN 51 821, is mentioned in the standard DIN 51 825 for testing rolling bearing greases. On this test rig, the grease service life is tested with rolling bearings as test specimens.

When using the FAG test system FE9, speeds, loads and mounting conditions can be freely selected. Also, the operating temperature can be varied by means of a heating system. Running times and power consumption are the criteria for evaluating the lubricity.

With the FAG test system FE8 (draft of DIN 51 819), the rolling bearing type and, to a limited extent, the bearing size can also be freely selected. Also, it is possible to measure the energy losses due to bearing friction and the bearing wear. The measured results must be backed by statistics because the measured values scatter widely.

MIL Specifications

Specifications of the US Armed Forces indicating the minimum mandatory requirements for the materials to be supplied. Some engine and machine builders apply the same minimum mandatory requirements to the lubricants. The MIL minimum mandatory requirements are taken as a quality standard.

Mineral Oils

Crude oils and/or their liquid derivatives.

Miscibility of Greases

-> Page 38

Miscibility of Oils

Oils of different grades or from different manufacturers should not be mixed at

random. The only exception are HD engine oils which can generally be mixed. If fresh oils are mixed with used oils, sludge can deposit. Whenever there is the risk of sludge formation, samples should be mixed in a beaker.

Multigrade Oils

Engine and gear oils with improved viscosity-temperature behaviour.

Neutralization Number NZ

The neutralization number NZ is a yardstick in assessing the deterioration of a mineral oil. It is expressed in milligrams of potassium hydroxide required to neutralize the free acids in one gram of oil. Due to the additives, the neutralization number of doped fresh oils is usually above zero. The neutralization number of a used oil should not differ from that of a new oil by more than 2.

NLGI Class

-> Penetration.

Nominal Viscosity

-> Viscosity.

Operating Viscosity

Kinematic viscosity of an oil at operating temperature. It is termed ν . The operating viscosity can be determined by means of a viscosity-temperature diagram. The operating viscosity of mineral oils with average viscosity-temperature behaviour can be determined by means of diagram 5.

Oil Separation

Oil can separate from the greases if they are stored for an extended period of time or temperatures are high. Oil separation is determined according to DIN 51 817. For-life lubrication requires a small, steady oil separation rate which must, however, be large enough to lubricate all contact areas.

Oxidation

-> Deterioration.

Penetration

Penetration is a measure of the consistency of a lubricating grease. It is determined by allowing a standard cone to sink into a grease sample and measuring the depth of penetration in tenths of a millimetre (time of penetration 5 s).

Worked penetration is the penetration of a grease sample that has been worked a standard amount of strokes at 25 °C. The penetration classes range from 000 bis 6 (DIN 51 81 8).

Penetration of common rolling bearing greases

Consistency classification to NLGI (Penetration classes)	Worked penetration [0.1 mm]
1	310-340
2	265-295
3	220-250
4	175-205

Pour Point

The pour point of a mineral oil is the lowest temperature at which an oil sample can just about flow, if cooled under specified conditions.

Pressure Viscosity

-> Viscosity-pressure behaviour.

Radiation

In addition to the SI units, the old units rd and rem are still used occasionally.

The absorbed dose is expressed in:

1 J/kg = 1 Gy (gray)

1 Gy = 100 rd (rad)

The dose equivalent is expressed in:

1 J/kg = 1 Sv (sievert)

100 rem = 1 Sv

1 rd = 1 rem

Glossary of Terms

Rated Viscosity

The rated viscosity is the kinematic viscosity attributed to a defined lubrication condition. It can be determined with diagram 6 by means of the mean bearing diameter and the bearing speed. By comparing the operating viscosity ν_1 with the operating viscosity ν the lubrication condition can be assessed.

Refined Oils

A satisfactory resistance to ageing of lubricating oils is obtained by refining the distillates in lubricating oil production. Unstable compounds which can incorporate sulphur, nitrogen, oxygen and metallic salts are removed. Several refining processes are used, the most important being the treatment with sulphuric acid (acid treatment) and the extraction of oil-insoluble unstable compounds with solvents (solvent refining).

Refrigerator Oils

These are used in refrigerators where they are exposed to the effects of the refrigerant. Refrigerator oils are classified according to the refrigerants used. The minimum requirements are specified in DIN 51 503.

Relubrication Interval

Period after which lubricant is replenished. The relubrication interval should be shorter than the lubricant renewal interval.

SAE Classification

In English speaking countries and in automotive engineering, the viscosity of lubricating oils is specified according to the SAE classification (Society of Automotive Engineers). Conversion of the SAE values for engine oils are indicated in DIN 51 511, and for automotive gear oils in DIN 51 512.

Saponification Number VZ

The condition of new and used mineral oils, including those with additives, can be assessed by means of the saponification number VZ. It is expressed in milligrams of potassium hydroxide which are required to neutralize the free and bonded acids in one gram of oil and to saponify the esters in the oil.

Saybolt Universal Viscosimeter

Viscosimeter used in the USA for determining the conventional viscosity in SSU (Second Saybolt Universal) or in SUS (Saybolt Universal Seconds).

Seals, Seal Compatibility

The reaction of sealing materials with mineral oils and greases differs widely. They can swell, shrink, embrittle or even dissolve, operating temperatures, lubricant composition and duration of exposure playing a major role. Seal and lubricant manufacturers should be consulted for seal compatibility.

Sediments

Sediments are mainly formed by lubricant residues, soot and dirt particles. They are caused by oil deterioration, mechanical wear under the influence of excessive heating and too long oil renewal intervals. They settle in the oil sump, in the bearings, in filters, and in lubricant feed lines. Sediments are hazardous to the operational reliability.

Semi-fluid Greases

These are lubricating greases of semi-fluid to pasty consistency. To improve their load carrying capacity, semi-fluid greases which are generally used for gear lubrication, can be doped with EP additives or solid lubricants.

Setting Point

The setting point of a lubricating oil is the temperature at which the oil ceases to

flow if cooled under specific conditions. It is 2 to 5 K lower than the pour point. The low-temperature behaviour of the oil slightly above the setting point may be unsatisfactory and must therefore be determined by measuring the viscosity.

Silicone Oils

Synthetic oils which are used for special operating conditions. They have better physical data than mineral oils, but have poorer lubricating properties and a low load carrying capacity. See also table in fig. 30.

Sludging

Air and water can effect the formation of oxidation products and polymerizates in mineral oil products. They settle as sludge.

Sodium Soap Base Greases

Sodium soap base greases adhere well to the bearing surfaces and form a uniform and smooth lubricating film on the rolling and sliding surfaces of rolling bearings. They tend to emulsify with water, i.e. they are not water resistant. The grease is able to absorb minor quantities of water without problem; larger amounts of water liquefy the grease and make it run out of the bearing. Sodium soap base greases have poor low-temperature properties. They can be used at temperatures ranging from approx. $-30\text{ }^{\circ}\text{C}$ and $+120\text{ }^{\circ}\text{C}$.

Solid Foreign Particles

All foreign contaminants insoluble in n-heptane and solvent compounds to DIN 51 813 are generally referred to as solid foreign particles. Solid foreign particles in lubricating oils are evaluated according to DIN 51 592 E, in greases according to DIN 51 813, in solvent compounds according to DIN 51 813.

Solvates

Mineral oils refined with solvents.

Specifications

Military and industrial standards for lubricants which stipulate physical and chemical properties as well as test methods.

Spindle oils

Low-viscosity lubricating oils with a viscosity of approximately 10 to 90 mm²/s at 40 °C.

Standard Lubricating Oils

Lubricating oils L-AN in accordance with DIN 51 501. They are used where no particular demands are placed on the lubricant.

Steam Turbine Oils

Highly refined, non-ageing oils (lubricating oils T) which are used for the lubrication of steam turbine gears and bearings. The oils are available with additives (EP) and without additives: DIN 51515 P1.

Suspension

Colloidal suspension of solid particles dispersed in liquids, e.g. oil-insoluble additives in lubricants.

Swelling Properties

The swelling properties of natural rubber and elastomers under the effect of lubricants are tested according to DIN 53 521.

Synthetic Lubricants

Lubricants produced by chemical synthesis; their properties can be adapted to meet special requirements: very low setting point, good V-T behaviour, small evaporation losses, long life, high oxidation stability.

Thickener

Thickener and base oil are the constituents of lubricating greases. The most

commonly used thickeners are metal soaps (lithium, calcium, sodium-12 hydroxystearates etc.) as well as polyurea, PTFE and magnesium aluminium silicate compounds.

Thixotropy

The property of a grease to become softer when mechanically stressed and to return to its original consistency when left to rest. Preserving oils with special additives are also thixotropic.

Unworked Static Penetration

Consistency of a grease sample, measured at 25 °C, which was not treated in a grease worker.

Viscosity

Viscosity is the most important physical property of a lubricating oil. It determines the load carrying capacity of the oil film under elastohydrodynamic lubricating conditions. Viscosity decreases with rising temperature and vice-versa (see V-T behaviour). Therefore, it is necessary to specify the temperature to which any given viscosity value applies. The nominal viscosity of an oil is its kinematic viscosity at 40 °C. See also "Viscosity Classification". Physically, the viscosity is the resistance which contiguous fluid strata oppose mutual displacement. Distinction is made between the dynamic viscosity η and the kinematic viscosity ν . The dynamic viscosity is the product of the kinematic viscosity and the density of a fluid: $\eta = \rho \cdot \nu$, ρ being the density. The SI Units (internationally agreed coherent system of units) for the dynamic viscosity are Pa s or mPa s. They have replaced the formerly used units Poise (P) and Centipoise (cP). Conversion: 1cP = 10⁻³ Pa s. The SI units for the kinematic viscosity are m²/s und mm²/s. The formerly used unit Centistoke (cSt) corresponds to the SI unit mm²/s.

Viscosity Classification

The standards ISO 3448 and DIN 51 519 specify 18 viscosity classes ranging

from 2 to 1500 mm²/s at 40 °C for industrial liquid lubricants (see table).

ISO Viscosity Classification:

Viscosity class	Viscosity at 40 °C mm ² /s	Limits of kinematic viscosity at 40 °C mm ² /s	
		min.	max.
ISO VG 2	2.2	1.98	2.42
ISO VG 3	3.2	2.88	3.52
ISO VG 5	4.6	4.14	5.06
ISO VG 7	6.8	6.12	7.48
ISO VG 10	10	9.00	11.0
ISO VG 15	15	13.5	16.5
ISO VG 22	22	19.8	24.2
ISO VG 32	32	28.8	35.2
ISO VG 46	46	41.4	50.6
ISO VG 68	68	61.2	74.8
ISO VG 100	100	90.0	110
ISO VG 150	150	135	165
ISO VG 220	220	198	242
ISO VG 320	320	288	352
ISO VG 460	460	414	506
ISO VG 680	680	612	748
ISO VG 1000	1000	900	1100
ISO VG 1500	1500	1350	1650

Viscosity Index VI

The viscosity index VI of an oil gives a measure of its viscosity-temperature behaviour.

Viscosity Index Improvers

Additives dissolved in mineral oil which improve the viscosity-temperature behaviour. At high temperatures, they increase the viscosity, at low temperatures they improve the flow properties (fluidity).

Viscosity-Pressure Behaviour

Viscosity of a lubricating oil as a function of pressure. With a rise in pressure the viscosity of mineral oils increases (diagram, fig. 3).

Glossary of Terms

V-T Behaviour

The term viscosity-temperature behaviour refers to the viscosity variations with temperatures. The V-T behaviour is good if the viscosity varies little with changing temperatures.

-> Viscosity Index (VI).

Water Content

If an oil contains water, the water droplets disrupt the lubricating film and reduce lubricity. Water in oil accelerates deterioration and leads to corrosion. The water content can be determined by distillation or by settling in a test tube; due to its higher specific gravity the water settles at the bottom. Samples of emulsifying oils must be heated. A small amount of water is identified by a crackling noise which is produced when the oil is heated in a test tube.

Water Resistance

The water resistance of lubricating greases is tested according to DIN 51 807 (static test); it is not indicative of the water resistance of the grease when used in the field. The test merely shows the effect which static, distilled water has on an unworked grease at different temperatures.

Water Separation Ability

Ability of an oil to separate water. The test is carried out according to DIN 51 589.

Worked Penetration

Consistency of lubricating greases at 25 °C measured by the penetration depth of a standard cone, after treatment of the grease sample in a grease worker (DIN 51 804 T2 and DIN ISO 2137).

Rolling Bearing Lubrication

Every care has been taken to ensure the correctness of the information contained in this publication but no liability can be accepted for any errors or omissions. We reserve the right to make changes in the interest of technical progress.

WL 81 115/4 EA/94/2/00

© by FAG 1997 · This publication or parts thereof may not be reproduced without our permission.
Printed in Germany by Weppert GmbH & Co. KG, Schweinfurt