



FAG tools for mechanical mounting and dismounting of rolling bearings

Contents

Mechanical mounting and dismantling of rolling bearings 2

Tools for mounting 4

Mounting tool set FITTING-TOOL-ALU-10-50	4
Mounting tool set FITTING-TOOL-STEEL-10-50	6

Tools for mounting and dismantling 8

Socket wrenches LOCKNUT-SOCKET	8
Hook wrenches LOCKNUT-HOOK	9
Jointed hook wrenches LOCKNUT-FLEXIHOOK	10
Jointed pin wrenches LOCKNUT-FLEXIPIN	11
Jointed face wrenches LOCKNUT-FACEPIN	12
Double hook wrenches LOCKNUT-DOUBLEHOOK	13

Tools for dismantling 15

Mechanical two-arm extractors 54	15
Mechanical two-arm bearing extractors 47	16
Mechanical three-arm extractors 52	17
Hydraulic pressure tool 44	18
Mechanical internal extractors 62	19
Mechanical internal extractors PULLER-INTERNAL10/100-SET	20
Mechanical ball bearing extractors 56	22
Mechanical special bearing extractors 64	24
Mechanical extraction device 49	26
Hydraulic standard extractors with integral hand pump	27
Extra strong hydraulic extractors with integral hand pump	28
Extra strong hydraulic extractors with separate hand pump	29
Three-section extraction plates for extractors	30

The designation system of the INA and FAG brands has been harmonised. This catalogue contains, for the first time, the new ordering designations, which are currently only valid for Europe. Customers outside Europe are requested to continue using the old ordering designations (please see the comparison on page 32).

Mechanical mounting and dismounting of rolling bearings

Mechanical mounting and dismounting of rolling bearings

Cylindrical bearing seats

Smaller bearings can be driven cold onto the shaft or into the housing for normal tight fits.

To prevent bearing damage, the fitting forces must always be applied to the tightly fitted ring.

FAG **mounting tool sets** allow cost-effective and safe **mounting** of rolling bearings with bore diameters of 10 to 50 mm or outside diameters of 16 to 110 mm. They can also be used to easily mount sleeves, intermediate rings, seals and similar parts. Tightly fitted inner rings can be driven onto the shaft or outer rings into the housing bore by hitting the mounting sleeve with the hammer. This prevents the mounting forces being transmitted through the rolling elements and raceways, which can lead to damage. The carefully matched FAG precision parts ensure that the forces are uniformly transmitted to the side faces of the bearing rings.

Great care is also required during **dismounting**. The extraction tool must always be applied to the ring to be removed.

Mechanical FAG **extractors** can be used to dismount small rolling bearings up to approx. 100 mm bore diameter that are located with a tight fit on a shaft or in a housing. The extraction force is normally applied by means of a threaded spindle.

A hydraulic spindle facilitates work with hydraulic FAG extractors for larger rolling bearings. Extraction forces of up to 400 kN (40 tonnes) can be generated in this case.

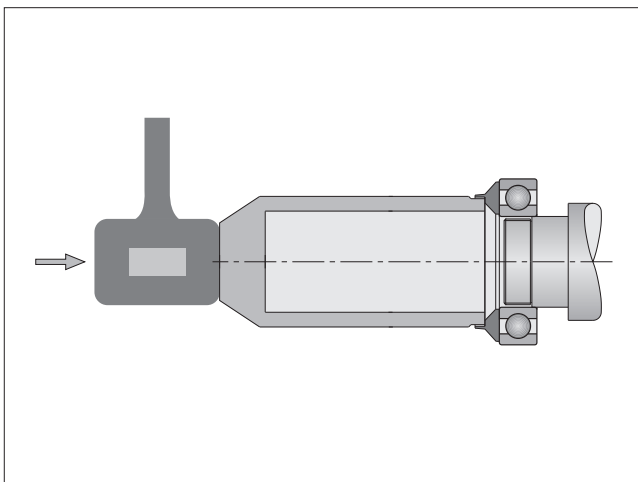

Appropriate mounting sleeves such as those included in the FAG mounting tool sets can be used to drive on small bearings using light hammer blows.

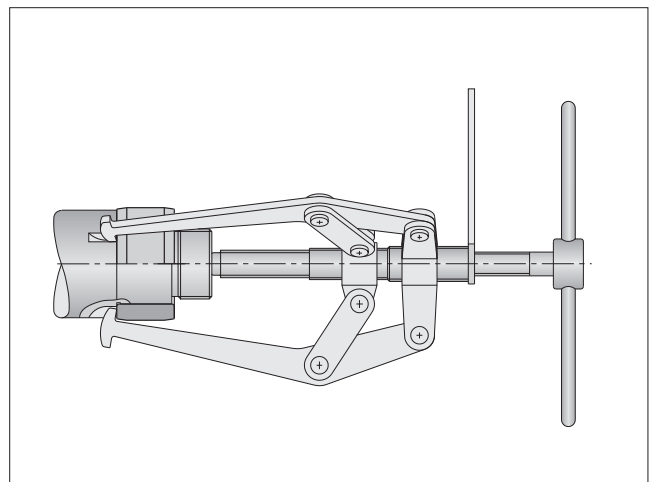

An extractor with adjustable arms grips under a tightly fitted inner ring. Dismounting can be made easier by means of extraction slots.

Mechanical mounting and dismounting of rolling bearings

Tapered bearing seats

The inner ring of a bearing with tapered bore is always mounted with a tight fit. The bearing can be either seated directly on a tapered shaft or fixed to a cylindrical shaft using an adapter or extraction sleeve. When the inner ring is pushed on, it is expanded and the radial internal clearance is reduced. The reduction in radial internal clearance is therefore valid as a measure of the seating of the inner ring. To prevent bearing damage, the inner ring must not be pushed on too far.

For guide values for the reduction in radial internal clearance, see FAG publication WL 80 100 "Mounting of rolling bearings". Feeler gauges for measuring the radial internal clearance are described in FAG publication IS 1 "Mounting and Maintenance of Rolling Bearings". Another method for measuring the correct internal clearance is measurement of the axial displacement.

Locknuts can be easily tightened and loosened on shafts, adapter sleeves and extraction sleeves using **socket wrenches**.

FAG **hook wrenches** can be used to tighten and loosen locknuts (precision locknuts) on shafts, adapter sleeves or extraction sleeves.

If no torque value is specified, jointed hook wrenches, jointed pin wrenches and jointed face wrenches can be used for locknuts and precision locknuts.

Double hook wrenches are engraved with the torsion angles for the appropriate self-aligning ball bearings. The displacement and reduction in radial internal clearance can therefore be precisely set. Both kits and sets contain suitable torque wrenches.

The FAG computer program **MOUNTING MANAGER** is a user-friendly aid for ensuring the correct mounting of bearings with tapered bore. It shows suitable mounting methods, calculates the data required for mounting in relation to reduction in radial internal clearance and displacement and generates a list of the accessories and tools required. A more detailed description of the computer program can be found in TPI WL 80-57 "FAG Hydraulic nuts".

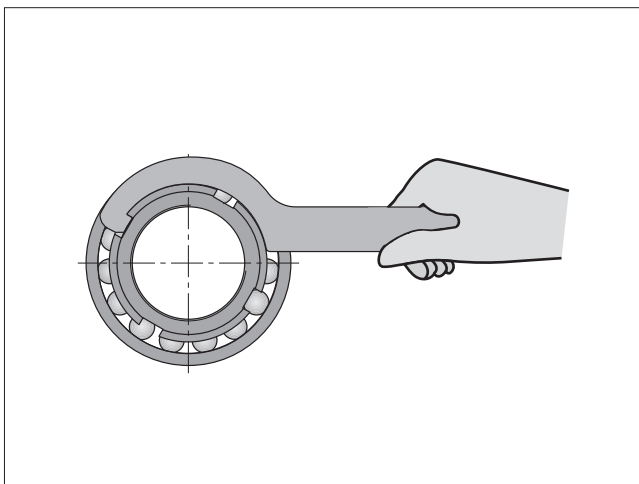

An FAG hook wrench is used to tighten shaft nuts, adapter sleeve nuts and extraction nuts simply and securely.

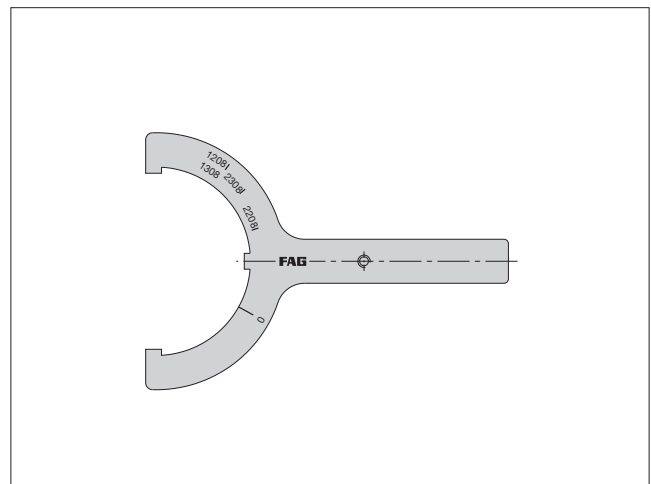

The FAG double hook wrench is engraved with the torsion angles for the appropriate self-aligning ball bearings.

FAG tools for mounting of rolling bearings

Mounting tool set FITTING-TOOL-ALU-10-50 for cylindrical bearing seats

FAG mounting tool set FITTING-TOOL-ALU-10-50

The FITTING-TOOL-ALU-10-50 allows particularly cost-effective mounting of many standardised rolling bearings (bore diameter of 10 to 50 mm) and other parts. The low mass of the components makes this mounting tool set very easy to handle.

Features

The tool set contains 33 different mounting rings and 3 mounting sleeves as well as a hammer. The mounting rings are made from impact-resistant plastic. This prevents metal/metal contact as well as damage to or premature wear of the bearing seatings. The mounting sleeves are made from aluminium. The head of the recoilless hammer (1 kg mass) produces no sparks. Each mounting sleeve can be pushed over the shaft end as far as 220 mm. The combination of mounting ring and mounting sleeve required for the application in question can be found in the table inside the lid of the case, see also page 5. The parts are driven on by hitting the mounting sleeve using the supplied hammer. The components of the tool set are housed in a practical case. Case dimensions:
440×350×95 mm

Included in delivery

33 mounting rings
3 mounting sleeves
1 hammer
1 case

Mass of complete tool set: 4,5 kg

Ordering designation for tool set:
FITTING-TOOL-ALU-10-50

Ordering examples for replacement parts

(available by agreement):

FITTING-TOOL-ALU.SLEEVE-A
(mounting sleeve A)

FITTING-TOOL-ALU.SLEEVE-B
(mounting sleeve B)

FITTING-TOOL-ALU.SLEEVE-C
(mounting sleeve C)

FITTING-TOOL-ALU.RING10/26
(mounting ring bore 10 mm,
outside diameter 26 mm)

FITTING-TOOL-ALU.RING50/110
(mounting ring bore 50 mm,
outside diameter 110 mm)

FITTING-TOOL-ALU.HAMMER
(hammer, recoilless)

FITTING-TOOL-ALU.CASE
(case for tool set)







FITTING-TOOL-ALU-10-50

FAG tools for mounting of rolling bearings

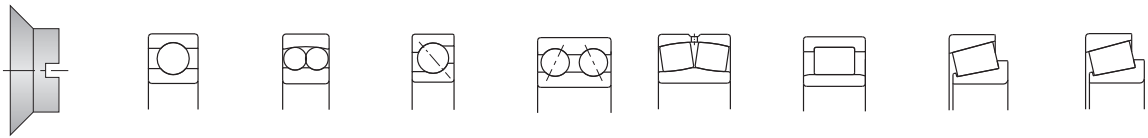
FITTING-TOOL-ALU-10-50 · Selection table

FITTING-TOOL-ALU-10-50



Mounting sleeve	Mounting ring no.	Series 60, 62 63, 64	Series 12, 22 13, 23	Series 72B 73B	Series 32 33	Series 213, 222 223	Series NU/NJ/N 2, 3, 4	Series 302, 303 322	Series 313 323
	10-26	6000							
	10-30	6200	1200		3200				
	10-35	6300	1300						
	12-28	6001							
	12-32	6201	1201		3201				
			2201						
	12-37	6301	1301						
			2301						
	15-32	6002							
	15-35	6202	1202	7202B	3202				
			2202						
	15-42	6302	1302		3302			30302	
			2302						
	17-35	6003							
	17-40	6203	1203	7203B	3203			30203	
		2203							
17-47	6303	1303	7303B	3303			30303		
		2303							
	20-42	6004							
	20-47	6204	1204	7204B	3204		204		
			2204						
	20-52	6304	1304	7304B	3304	21304	304	30304	32304
		6403	2304						
	25-47	6005							
	25-52	6205	1205	7205B	3205	22205	205	30205	
			2205						
	25-62	6305	1305	7305B	3305	21305	305	30305	31305
		6404	2305						32305
	30-55	6006							
	30-62	6206	1206	7206B	3206	22206	206	30206	
			2206					32206	
	30-72	6306	1306	7306B	3306	21306	306	30306	31306
		6405	2306				405		32306
	35-62	6007							
	35-72	6207	1207	7207B	3207	22207	207	30207	
			2207					32207	
	35-80	6307	1307	7307B	3307	21307	307	30307	31307
		6406	2307				406		32307
	40-68	6008							
	40-80	6208	1208	7208B	3208	22208	208	30208	
			2208					32208	
	40-90	6308	1308	7308B	3308	21308	308	30308	31308
		6407	2308			22308	407		32308
	45-75	6009							
	45-85	6209	1209	7209B	3209	22209	209	30209	
			2209					32209	
	45-100	6309	1309	7309B	3309	21309	309	30309	31309
		6408	2309			22309	408		32309
50-80	6010								
50-90	6210	1210	7210B	3210	22210	210	30210		
		2210					32210		
50-110	6310	1310	7310B	3310	21310	310	30310	31310	
	6409	2310			22310	409		32310	

If only bearing outer rings have to be installed, for example when the shaft is dismantled, the mounting rings no. 50-90, no. 45-100 and no. 50-110 are used according to the following table.

	50-90	6011							
		6012							
	45-100	6013	1211	7211B	3211	22211	211		
		6211	2211						
	50-110	6014	1212	7212B	3212	22212	212		
		6015	1213	7213B	3213	22213	213		
		6212	2212	7311B	3311	21311	311		
		6213	2213			22311	410		
		6311	1311						
		6410	2311						

FAG tools for mounting of rolling bearings

Mounting tool set FITTING-TOOL-STEEL-10-50 for cylindrical bearing seats

FAG mounting tool set FITTING-TOOL-STEEL-10-50

The mounting tool set FITTING-TOOL-STEEL-10-50 is designed for very high loads and a long operating life. The tools can also be used for pressing in or out on workshop power presses. The tool set can be used for the mounting of rolling bearings with a bore diameter of 10 to 50 mm.

Features

The tool set contains 33 different hardened mounting rings and 5 mounting sleeves made from tool steel. The nylon head of the recoilless hammer (0.7 kg mass) produces no sparks. Each mounting sleeve can be pushed over the shaft end as far as 220 mm. The combination of mounting ring and mounting sleeve required for the application in question can be found in the table inside the lid of the case, see also page 7. Integrated O rings allow parts to be joined together securely. The parts are driven on by hitting the mounting sleeve with the supplied hammer. The components of the tool set are housed in a practical metal case. Case dimensions:
370×320×70 mm

Included in delivery

- 33 mounting rings
- 5 mounting sleeves
- 1 hammer
- 1 metal case

Mass of complete tool set: 21 kg

Ordering designation for tool set:
FITTING-TOOL-STEEL-10-50

Ordering examples for replacement parts

(available by agreement):

FITTING-TOOL-STEEL.SLEEVE-B
(mounting sleeve B)

FITTING-TOOL-STEEL.SLEEVE-C
(mounting sleeve C)

FITTING-TOOL-STEEL.SLEEVE-E
(mounting sleeve E)



FITTING-TOOL-STEEL-10-50

FAG tools for mounting of rolling bearings

FITTING-TOOL-STEEL-10-50 · Selection table

FITTING-TOOL-STEEL-10-50

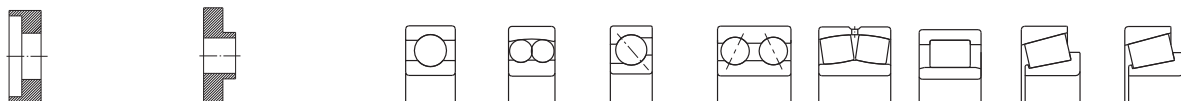

Mounting sleeve	Mounting ring no.	Series 60, 62 63, 64	Series 12, 22 13, 23	Series 72B 73B	Series 32 33	Series 213, 222 223	Series NU/NJ/N 2, 3, 4	Series 302, 303 322	Series 313 323
A	1 (10/26 mm)	6000							
	2 (10/30 mm)	6200	1200		3200				
	3 (10/35 mm)	6300	1300						
	4 (12/28 mm)	6001							
	5 (12/32 mm)	6201	1201		3201				
	6 (12/37 mm)	6301	1301						
B	7 (15/32 mm)	6002							
	8 (15/35 mm)	6202	1202	7202B	3202				
	9 (15/42 mm)	6302	1302		3302			30302	
	10 (17/35 mm)	6003							
	11 (17/40 mm)	6203	1203	7203B	3203				30203
	12 (17/47 mm)	6303	1303	7303B	3303				30303
C	13 (20/42 mm)	6004							
	14 (20/47 mm)	6204	1204	7204B	3204		204		
	15 (20/52 mm)	6304	1304	7304B	3304	21304	304	30304	32304
	16 (25/47 mm)	6403	2304						
	17 (25/52 mm)	6005							
	18 (25/62 mm)	6205	1205	7205B	3205	22205	205	30205	
D	19 (30/55 mm)	6305	1305	7305B	3305	21305	305	30305	31305
	20 (30/62 mm)	6404	2305						32305
		6006							
		6206	1206	7206B	3206	22206	206	30206	
		6306	1306	7306B	3306	21306	306	30306	31306
		6405	2306				405		32306
E	21 (30/72 mm)	6007							
	22 (35/62 mm)	6207	1207	7207B	3207	22207	207	30207	
	23 (35/72 mm)	6307	1307	7307B	3307	21307	307	30307	31307
	24 (35/80 mm)	6406	2307				406		32307
	25 (40/68 mm)	6008							
	26 (40/80 mm)	6208	1208	7208B	3208	22208	208	30208	
E	27 (40/90 mm)	6308	1308	7308B	3308	21308	308	30308	
	28 (45/75 mm)	6407	2308			22308	407		
	29 (45/85 mm)	6009							
	30 (45/100 mm)	6209	1209	7209B	3209	22209	209	30209	
	31 (50/80 mm)	6309	1309	7309B	3309	21309	309	30309	31309
	32 (50/90 mm)	6408	2309			22309	408		32309
E	33 (50/110 mm)	6010							
		6210	1210	7210B	3210	22210	210	30210	
		6310	1310	7310B	3310	21310	310	30310	31310
		6409	2310			22310	409		32310

If only bearing outer rings have to be installed, for example when the shaft is dismantled, the mounting rings no. 32 (50/90 mm), no. 30 (45/100 mm) and no. 33 (50/110 mm) are used according to the following table.

E	32 (50/90 mm)	6011							
		6012							
	30 (45/100 mm)	6013	1211	7211B	3211	22211	211		
		6211	2211						
	33 (50/110 mm)	6014	1212	7212B	3212	22212	212		
		6015	1213	7213B	3213	22213	213		
		6212	2212	7311B	3311	21311	311		
		6213	2213			22311	410		
		6311	1311						
		6410	2311						

FAG tools for mounting and dismounting of rolling bearings

Socket wrenches for tapered bearing seats

FAG socket wrenches LOCKNUT-SOCKET-KM...

Locknuts KM0 to KM20 can be easily tightened and loosened on shafts, adapter sleeves or extraction sleeves using socket wrenches LOCKNUT-SOCKET-KM...

They require less space on the circumference of the nut than hook wrenches and allow the use of ratchets and torque wrenches. For increased reliability, socket wrenches should be secured using a locking pin and rubber washer. FAG socket wrenches therefore have a hole for the locking pin and a groove for the rubber washer.

The locking pin and rubber washer are included in delivery.

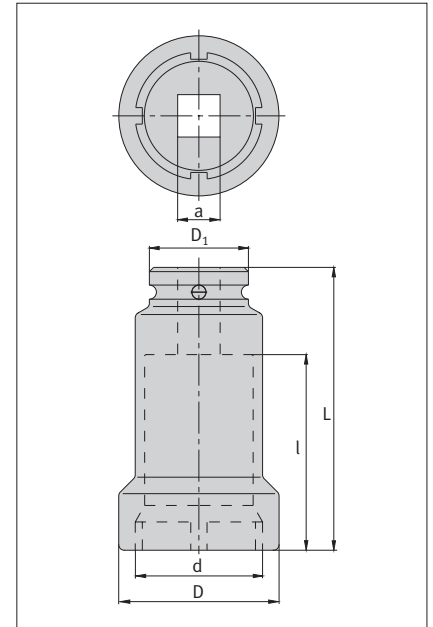

Technical data

Socket wrench	Dimensions					Square a inch	Mass ≈ kg	Suitable for nut FAG
	d mm	D	D ₁	L	l			
LOCKNUT-SOCKET-KM0	18,1	22	22	57	44	3/8	0,1	KM0
LOCKNUT-SOCKET-KM1	22,2	28	22	57	44	3/8	0,1	KM1
LOCKNUT-SOCKET-KM2	25,2	33	30	82	60	1/2	0,2	KM2
LOCKNUT-SOCKET-KM3	28,2	36	30	82	60	1/2	0,24	KM3
LOCKNUT-SOCKET-KM4	32,2	38	30	82	56	1/2	0,28	KM4
LOCKNUT-SOCKET-KM5	38,2	46	30	82	56	1/2	0,38	KM5
LOCKNUT-SOCKET-KM6	45,2	53	30	82	56	1/2	0,42	KM6
LOCKNUT-SOCKET-KM7	52,2	60	30	82	56	1/2	0,45	KM7
LOCKNUT-SOCKET-KM8	58,3	68	30	82	56	1/2	0,61	KM8
LOCKNUT-SOCKET-KM9	65,4	73,5	44	90	62	3/4	0,8	KM9
LOCKNUT-SOCKET-KM10	70,4	78,5	44	90	62	3/4	0,85	KM10
LOCKNUT-SOCKET-KM11	75,4	83,5	44	90	62	3/4	0,9	KM11
LOCKNUT-SOCKET-KM12	80,4	88,5	44	90	60	3/4	1	KM12
LOCKNUT-SOCKET-KM13	85,4	94	44	90	60	3/4	1,1	KM13
LOCKNUT-SOCKET-KM14	92,5	103	76	110	74	1	2,2	KM14
LOCKNUT-SOCKET-KM15	98,5	109	76	110	74	1	2,3	KM15
LOCKNUT-SOCKET-KM16	105,6	116	76	110	74	1	2,45	KM16
LOCKNUT-SOCKET-KM17	110,6	121	76	110	72	1	2,6	KM17
LOCKNUT-SOCKET-KM18	120,6	131	76	110	72	1	2,9	KM18
LOCKNUT-SOCKET-KM19	125,6	137	76	110	72	1	3,05	KM19
LOCKNUT-SOCKET-KM20	130,6	143	76	110	70	1	3,3	KM20

Other sizes by agreement.

FAG tools for mounting and dismounting of rolling bearings

Hook wrenches for tapered bearing seats

FAG socket wrenches LOCKNUT-HOOK-KM...

FAG hook wrenches of series LOCKNUT-HOOK-KM... can be used to tighten and loosen locknuts of size KM0 and larger on shafts, adapter sleeves and extraction sleeves.

Hook wrenches can be used to mount rolling bearings on tapered shaft seats, adapter sleeves or extraction sleeves. Extraction sleeves can also be dismounted using hook wrenches together with the extraction nuts. The table below contains dimensions, masses and allocation of the hook wrenches to the respective locknuts.

Ordering example for FAG socket wrench, suitable for threaded nuts KM18, KM19 and KM20:

LOCKNUT-HOOK-KM18-20



Technical data

Hook wrench	Dimensions		Mass	Suitable for
Ordering designation	l	s	≈ kg	locknuts FAG
	mm			
LOCKNUT-HOOK-KM0-1	110	3	0,025	KM0, KM1
LOCKNUT-HOOK-KM2-3	136	4	0,045	KM2, KM3
LOCKNUT-HOOK-KM4	136	4	0,05	KM4
LOCKNUT-HOOK-KM5	170	5	0,09	KM5
LOCKNUT-HOOK-KM6	206	6	0,155	KM6
LOCKNUT-HOOK-KM7	206	6	0,16	KM7
LOCKNUT-HOOK-KM8-9	242	7	0,255	KM8, KM9
LOCKNUT-HOOK-KM10-11	242	7	0,255	KM10, KM11
LOCKNUT-HOOK-KM12-14	280	8	0,41	KM12, KM13, KM14
LOCKNUT-HOOK-KM15-16	280	8	0,385	KM15, KM16
LOCKNUT-HOOK-KM17	335	10	0,745	KM17
LOCKNUT-HOOK-KM18-20	335	10	0,72	KM18, KM19, KM20
LOCKNUT-HOOK-KM21-23	385	10	1	KM21, KM22, KM23
LOCKNUT-HOOK-KM24-27	385	10	1,16	KM24, KM25, KM26, KM27
LOCKNUT-HOOK-KM28-30	470	10	1,58	KM28, KM29, KM30
LOCKNUT-HOOK-KM31-34	470	10	1,58	KM31, KM32, KM33, KM34
LOCKNUT-HOOK-KM36-40	560	10	2,25	KM36, KM38, KM40

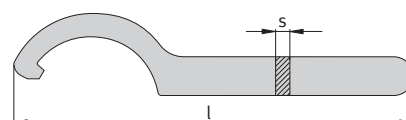

Other sizes by agreement.

FAG tools for mounting and dismounting of rolling bearings

Jointed hook wrenches for tapered bearing seats

FAG jointed hook wrenches LOCKNUT-FLEXIHOOK-KM...

FAG jointed hook wrenches of series LOCKNUT.FLEXI-HOOK-KM... can be used to tighten and loosen locknuts KM.. as well as precision locknuts ZM... and ZMA... on shafts, adapter sleeves and extraction sleeves if no torque value is specified.

Due to the joint, it is possible to use a single hook wrench of series LOCKNUT-FLEXIHOOK-KM... to mount or dismount locknuts of various sizes.

Ordering example for FAG jointed hook wrench, suitable for locknuts KM14 to KM24:
LOCKNUT-FLEXIHOOK-KM14-24



Technical data

Jointed hook wrench	Dimensions		Mass	Suitable for	Precision locknut (INA)	
	Length	Thickness	≈	nut		
Ordering designation	mm		kg			
LOCKNUT-FLEXIHOOK-KM1-4	135	4	0,05	KM1	ZM12	
				KM2	ZM15	
				KM3	ZM17	
				KM4	ZM20	ZMA15/33
LOCKNUT-FLEXIHOOK-KM5-8	175	5	0,1	KM5	ZM25	ZMA20/38; ZMA20/52
				KM6	ZM30	ZMA25/45; ZMA25/58
				KM7	ZM35	ZMA30/52
				KM8	ZM40	ZMA35/58
LOCKNUT-FLEXIHOOK-KM9-13	250	7	0,28	KM9	ZM45	ZMA30/65
				KM10	ZM50	ZMA35/70
				KM11	ZM55	ZMA40/62; ZMA40/75
				KM12	ZM60	ZMA45/68; ZMA45/85
				KM13	ZM65	ZMA50/75
LOCKNUT-FLEXIHOOK-KM14-24	290	8	0,46	KM14	ZM70	ZMA50/92
				KM15	ZM75	ZMA55/98
				KM16	ZM80	ZMA60/98
				KM17	ZM85	ZMA65/105
				KM18	ZM90	ZMA70/110
				KM19		ZMA75/125
				KM20	ZM100	ZMA80/120
				KM21	ZM105	ZMA90/130; ZMA90/155
				KM22	ZM110	ZMA100/140
				KM23	ZM115	
				KM24	ZM120	
LOCKNUT-FLEXIHOOK-KM24-36	420	8	1	KM24	ZM120	ZMA90/155
				KM25	ZM125	
				KM26	ZM130	
				KM27		
				KM28	ZM140	
				KM29		
				KM30	ZM150	
				KM31		
				KM32		
				KM33		
				KM34		
				KM36		

FAG tools for mounting and dismounting of rolling bearings

Jointed pin wrenches for tapered bearing seats

FAG jointed pin wrenches LOCKNUT-FLEXIPIN-AM...

FAG jointed pin wrenches of series LOCKNUT-FLEXIPIN-KM... can be used to tighten and loosen precision locknuts AM15 to AM90 on shafts if no torque value is specified. FAG jointed pin wrenches can be used to mount small bearings on tapered shaft seats.

Tightening is achieved by means of axially arranged holes.

Ordering example for FAG jointed pin wrench, suitable for locknuts AM35 to AM60:
LOCKNUT-FLEXIPIN-AM35-60



Technical data				
Jointed pin wrench	Dimensions Length	Pin diameter	Mass ≈	Suitable for precision locknut (INA)
Ordering designation	mm		kg	
LOCKNUT-FLEXIPIN-AM15-17	135	4	0,05	AM15 AM17
LOCKNUT-FLEXIPIN-AM20	175	4	0,1	AM20
LOCKNUT-FLEXIPIN-AM25-35/58	175	5	0,1	AM25 AM30 AM35/58
LOCKNUT-FLEXIPIN-AM35-60	250	6	0,28	AM35 AM40 AM45 AM50 AM60
LOCKNUT-FLEXIPIN-AM70-90	290	8	0,46	AM70 AM90

FAG tools for mounting and dismounting of rolling bearings

Jointed face wrenches for tapered bearing seats

FAG jointed face wrenches LOCKNUT-FACEPIN-LNP...

FAG jointed face wrenches of series LOCKNUT-FACEPIN-LNP... can be used to tighten and loosen precision locknuts LNP017 to LNP170 on shafts if no torque value is specified. FAG jointed face wrenches can be used to mount small bearings on tapered shaft seats.

Tightening is achieved by means of axially arranged holes.

Ordering example for FAG jointed face wrench, suitable for precision locknuts LNP017 to LNP025:
LOCKNUT-FACEPIN-LNP17-25



Technical data				
Jointed face wrench	Dimensions Length	Pin diameter	Mass ≈	Suitable for precision locknut
Ordering designation	mm		kg	
LOCKNUT-FACEPIN-LNP17-25	150	4	0,09	LNP017 LNP020 LNP025
LOCKNUT-FACEPIN-LNP35-40	220	5	0,245	LNP035 LNP040
LOCKNUT-FACEPIN-LNP45-65	220	6	0,245	LNP045 LNP050 LNP055 LNP060 LNP065
LOCKNUT-FACEPIN-LNP70-75	320	7	0,67	LNP070 LNP075
LOCKNUT-FACEPIN-LNP80-100	320	8	0,67	LNP080 LNP085 LNP090 LNP095 LNP100
LOCKNUT-FACEPIN-LNP110-130	450	8	1,75	LNP110 LNP120 LNP130
LOCKNUT-FACEPIN-LNP140-170	450	10	1,75	LNP140 LNP150 LNP160 LNP170

FAG tools for mounting and dismounting of rolling bearings

Double hook wrenches for tapered bearing seats

FAG double hook wrenches for tapered bearing seats

FAG double hook wrenches are intended for the mounting of self-aligning ball bearings with a tapered bore. They are available as kits, sets or individual wrenches (for a description see below).

FAG double hook wrench kits LOCKNUT-DOUBLEHOOK-KM...-KIT

FAG double hook wrench kits comprise a case containing **one** double hook wrench, one torque wrench and a user manual. The torque wrench allows a precisely defined tightening torque to be achieved at the start of the mounting operation.

FAG double hook wrench sets LOCKNUT-DOUBLEHOOK-KM...-SET

FAG offers two different double hook wrench sets. The smaller set contains four double hook wrenches, while the larger set contains five. The other items in the case are the same as in the kits.

FAG double hook wrenches LOCKNUT-DOUBLEHOOK-KM...

Individual double hook wrenches are also available, see table on page 14 below. Each double hook wrench is engraved with the torsion angles for the self-aligning ball bearings to be mounted using that particular wrench, so that the displacement and reduction in radial internal clearance can be precisely set.



Double hook wrench kits, e. g. LOCKNUT-DOUBLEHOOK-KM5-KIT and LOCKNUT-DOUBLEHOOK-KM13-KIT



Double hook wrench sets LOCKNUT-DOUBLEHOOK-KM5-8-SET and LOCKNUT-DOUBLEHOOK-KM9-13-SET



Double hook wrenches, e. g. LOCKNUT-DOUBLEHOOK-KM5 and LOCKNUT-DOUBLEHOOK-KM13

FAG tools for mounting and dismounting of rolling bearings

Double hook wrenches for tapered bearing seats

Double hook wrench						
Double hook wrench kits	Suitable for self-aligning ball bearings				Adapter sleeve nut	Mass of kit ≈ kg
Ordering designation					FAG	
LOCKNUT-DOUBLEHOOK-KM5-KIT	1205	2205	1305	2305	KM5	1,35
LOCKNUT-DOUBLEHOOK-KM6-KIT	1206	2206	1306	2306	KM6	1,35
LOCKNUT-DOUBLEHOOK-KM7-KIT	1207	2207	1307	2307	KM7	1,35
LOCKNUT-DOUBLEHOOK-KM8-KIT	1208	2208	1308	2308	KM8	1,4
Contents of a kit:	1 double hook wrench (left hand column below), torque wrench with adjusting key (same as small set), case (350×220×65 mm), user manual					
LOCKNUT-DOUBLEHOOK-KM9-KIT	1209	2209	1309	2309	KM9	3,8
LOCKNUT-DOUBLEHOOK-KM10-KIT	1210	2210	1310	2310	KM10	3,8
LOCKNUT-DOUBLEHOOK-KM11-KIT	1211	2211	1311	2311	KM11	3,85
LOCKNUT-DOUBLEHOOK-KM12-KIT	1212	2212	1312		KM12	3,85
LOCKNUT-DOUBLEHOOK-KM13-KIT	1213	2213			KM13	4
Contents of a kit:	1 double hook wrench (right hand column below), torque wrench with adjusting key, extension piece (same as large set), case (450×330×100 mm), user manual					

Double hook wrench sets

Ordering designation:

LOCKNUT-DOUBLEHOOK-KM5-8-SET

Included in delivery: 4 double hook wrenches (left hand column below) torque wrench with adjusting key **LOCKNUT-DOUBLEHOOK.WRENCH35**, case (350×220×65 mm), user manual, total mass 1,5 kg

LOCKNUT-DOUBLEHOOK-KM9-13-SET

Included in delivery: 5 double hook wrenches (right hand column below) torque wrench with adjusting key **LOCKNUT-DOUBLEHOOK.WRENCH100**, extension piece **LOCKNUT-DOUBLEHOOK.LEVER**, case (450×330×100 mm), user manual, total mass 4,2 kg

Double hook wrench

Individual wrenches included in the small set

Individual wrenches included in the large set

Ordering designation

LOCKNUT-DOUBLEHOOK-KM5
LOCKNUT-DOUBLEHOOK-KM6
LOCKNUT-DOUBLEHOOK-KM7
LOCKNUT-DOUBLEHOOK-KM8

LOCKNUT-DOUBLEHOOK-KM9
LOCKNUT-DOUBLEHOOK-KM10
LOCKNUT-DOUBLEHOOK-KM11
LOCKNUT-DOUBLEHOOK-KM12
LOCKNUT-DOUBLEHOOK-KM13

The following **replacement parts** are available:
 individual double hook wrenches (see list of ordering designations above),
 torque wrench **LOCKNUT-DOUBLEHOOK.WRENCH35** or **LOCKNUT-DOUBLEHOOK.WRENCH100**,
 extension piece **LOCKNUT-DOUBLEHOOK.LEVER** for large set.

FAG tools for dismounting of rolling bearings

Mechanical two-arm extractors 54 for small bearings

FAG two-arm extractors 54

Application

- For extracting complete rolling bearings of all types or tightly fitted inner rings as well as other parts, e.g. gears, that are gripped from inside or outside
- Good radial and axial accessibility of the bearing location, possibly by means of slots, is required.

Operation and handling

An extractor of suitable dimensions is selected in accordance with the bearing size and the mounting conditions. The extraction arms are adjusted on the cross arm until they have the correct span.

A self-locking device prevents the arms from slipping off when the spindle is screwed in.

Rolling bearing rings that are removed in accordance with the specifications remain undamaged. If the extraction forces are directed through the rolling elements during extraction of complete bearings, the bearings are generally rendered unusable.

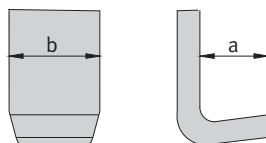

Product range - two-arm extractors 54

Ordering designation	Span	Depth	Dimensions		Spindle thread	Extraction force	Mass
Two-arm extractor	mm	mm	a	b		kN	≈ kg
			mm				

PULLER54-SET, comprising a stand (WxDxH) 215×235×475 mm complete with the following 6 extractors

							15,5
PULLER54-100	80	100	14 + 1	18 + 1	M14×1,5	40	0,75
PULLER54-200	120	125	14 + 1	18 + 1	M14×1,5	40	0,9
PULLER54-300	160	150	18 + 1	26 + 2	M20×2	60	2,3
PULLER54-400	200	175	18 + 1	26 + 2	M20×2	60	2,5
PULLER54-500	250	200	20 + 1	28 + 2	M22×2	85	3,45
PULLER54-600	350	250	20 + 1	28 + 2	M22×2	85	4,4

FAG tools for dismantling of rolling bearings

Mechanical two-arm extractors 47 for small bearings

FAG two-arm bearing extractors 47

Application

- For extracting complete rolling bearings or tightly fitted inner rings.
- Bearing rings can be in full contact with a surface, i.e. slots are not required.

Operation and handling

An extractor of suitable dimensions is selected in accordance with the bearing size and the mounting conditions. By means of the tightening shackle, the ring to be extracted can be wedged loose using the specially shaped arms. Wedging and centring on the shaft are important for extraction without damage.

Rolling bearing rings that are removed in accordance with the specifications remain undamaged. If the extraction forces are directed through the rolling elements during extraction of complete bearings, the bearings are generally rendered unusable.

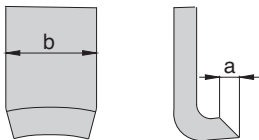

Product range - two-arm bearing extractors 47							
Ordering designation	Span	Depth	Dimensions		Spindle thread	Extraction force	Mass
Two-arm bearing extractor	mm	mm	a mm	b		kN	kg
PULLER47-100	45	65	2,5	12 + 1	M10	10	0,55
PULLER47-200	90	100	2,5	14 + 1	M14×1,5	40	1,45

FAG tools for dismounting of rolling bearings

Mechanical three-arm extractors 52 for small bearings

FAG three-arm extractors 52

Application

- For extracting complete rolling bearings or tightly fitted inner rings.
- Good radial and axial accessibility of the bearing location, possibly by means of slots, is required.

Operation and handling

An extractor of suitable dimensions is selected in accordance with the bearing size and the mounting conditions. The span is adjusted by shifting the lever system on the cylinder. The lever system causes self-locking of the arms, thereby ensuring good grip during the extraction process.

Rolling bearing rings that are removed in accordance with the specifications remain undamaged. If the extraction forces are directed through the rolling elements during extraction of complete bearings, the bearings are generally rendered unusable.

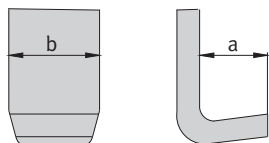

Product range - three-arm extractors 52

Ordering designation Three-arm extractor	Span	Depth	Dimensions		Spindle thread	Extraction force kN	Mass ≈ kg
	mm	mm	a mm	b			
PULLER52-085	85	65	5 + 1	6,5 + 1	M10	10	0,36
PULLER52-130	130	105	14 + 1	15 + 1	M14×1,5	40	2,4
PULLER52-230	230	150	19 + 1	22 + 1	M22×2	100	5,4
PULLER52-295	295	235	19 + 1	22 + 1	M22×2	100	6,2
PULLER52-390	390	270	20 + 2	30 + 2	M30×2	150	12,3
PULLER52-640	640	300	22 + 2	34 + 2	M30×2	150	15,8

FAG tools for dismantling of rolling bearings

Hydraulic pressure tool 44 for small bearings

Hydraulic FAG pressure tool 44

Application

The pressure tool is normally used to loosen tightly fitted parts in conjunction with mechanical extractors.

Operation and handling

The hydraulic pressure tool generates an axial force of 80 or 150 kN, thus bringing about a significant reduction in the effort required. The spindle thread of the mechanical extraction tool is not unduly stressed as the main extraction force acts on static thread flanks.

The pressure tool PULLER44-150 features a hydraulic return mechanism, i.e. when the pressure screw is reversed, the hydraulic system automatically returns to the initial position.

The hydraulic pressure tool is applied between the shaft end and extractor spindle. The spindle is then activated. The hydraulic system is actuated by screwing in the pressure screw. The axial force generated in this way loosens the part. It can then be extracted in the normal manner with the mechanical spindle.

For safety reasons, the minimum spindle diameter and the maximum torque (see table) must be observed.



Product range - hydraulic pressure tool 44						
Ordering designation	Axial force	Stroke	Section height	Spindle diameter min.	Torque max.	Mass ≈
Hydraulic pressure tool	kN	mm	mm	mm	Nm	kg
PULLER44-080	80	7	35	M22	25	0,6
PULLER44-150	150	10	85	M30	50	1,74

FAG tools for dismounting of rolling bearings

Mechanical internal extractors 62 for small bearings

FAG internal extractors 62

Application

- For deep groove ball bearings and angular contact ball bearings. The internal extractor set comprises nine extractors and can be used on bearings with a bore diameter from 5 mm to approx. 70 mm.
- For tightly fitted outer rings.
- The inner ring bore must be easily accessible.
- Since the extraction force is directed through the rolling elements, the possibility of bearing damage cannot be excluded.

Operation and handling

The gripper segments spread out when the threaded spindle is tightened. The lip of the jaws is pressed against the back of the bearing inner ring bore. The bearing is extracted using the threaded spindle and the internal extractor with the aid of the countersupport.



Ordering designation:
PULLER62-SET (nine internal extractors with two countersupports

in a rigid metal case). The nine internal extractors with countersupport can also be ordered individually.

Product range - internal extractor set 62 with countersupports

Ordering designation 9 internal extractors with 2 countersupports (set complete in case)	Internal extractor with countersupport	For inside diameter		Depth mm	Spindle thread	Mass ≈ kg
		from mm	to			
PULLER62-SET	PULLER62-100-005	5	6,5	35	M10	0,09
	PULLER62-100-007	7	9,5	35	M10	0,09
	PULLER62-100-010	10	13,5	35	M10	0,1
	PULLER62-100-014	14	19,5	45	M10	0,13
	PULLER62-100-020	20	29,5	50	M10	0,18
	PULLER62-100-030	30	39,5	90	M10	0,25
	PULLER62-200-040	40	49,5	95	M14×1,5	0,48
	PULLER62-200-050	50	59,5	95	M14×1,5	0,56
	PULLER62-200-060	60	69,5	95	M14×1,5	0,62

FAG tools for dismantling of rolling bearings

Mechanical internal extractors PULLER-INTERNAL10/100-SET

FAG internal extractors PULLER-INTERNAL10/100-SET

Application

- For standard deep groove ball bearings. The set, comprising 6 sets of extraction legs and 2 threaded spindles can be used on bores from 10 to 100 mm.
- For tightly fitted outer rings.
- No dismantling of shaft.

Function

Three extraction legs grip under the outer ring shoulder of the deep groove ball bearing. The suitable combination of extraction legs and threaded spindle for the bearing size can be found in the selection table.

Ordering designation:

PULLER-INTERNAL10/100-SET

(6 sets of extraction legs and 2 threaded spindles in a practical case, case dimensions: 315×250×70 mm, total mass: 3,2 kg)

The individual parts can be ordered separately, see page 21 below.



FAG tools for dismounting of rolling bearings

Mechanical internal extractors PULLER-INTERNAL10/100-SET

Selection table for extraction legs and spindles for internal extractor PULLER-INTERNAL10/100-SET

Deep groove ball bearing series				Extraction leg	Spindle
60	62	63	64		
6000	6200			A1	M12
6001					
6002					
6003				A2	
6004	6201				
6005	6202				
6006	6203			A3	
6007	6204	6300			
6008	6205	6301			
6009		6302		A4	
6010					
6011	6206	6303			
6012		6304		A5	
6013					
6014	6207	6305	6403		
6015	6208	6306		A6	
6016	6209	6307			
6017	6210				
	6211			M16	
6018	6212	6308	6404		
6019	6213	6309	6405		
6020	6214	6310	6406	A6	
	6215	6311	6407		
	6216	6312	6408		
	6217	6313	6409		
			6410		

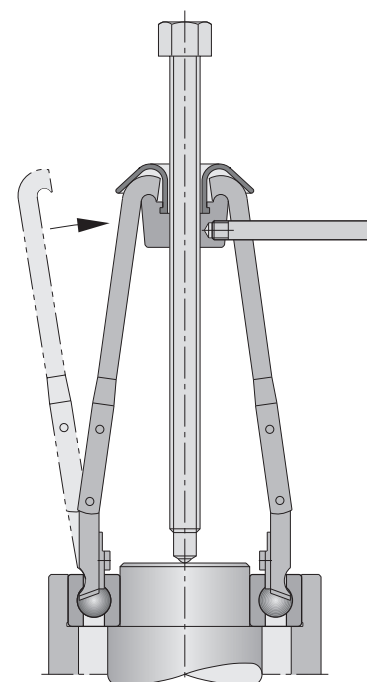

Replacement parts

Ordering designation	Description
PULLER-INTERNAL.ARM-A1-KIT	Three extraction legs, size A1, 140 mm long
PULLER-INTERNAL.ARM-A2-KIT	Three extraction legs, size A2, 140 mm long
PULLER-INTERNAL.ARM-A3-KIT	Three extraction legs, size A3, 140 mm long
PULLER-INTERNAL.ARM-A4-KIT	Three extraction legs, size A4, 170 mm long
PULLER-INTERNAL.ARM-A5-KIT	Three extraction legs, size A5, 170 mm long
PULLER-INTERNAL.ARM-A6-KIT	Three extraction legs, size A6, 170 mm long
PULLER-INTERNAL.SPINDLE-M12	Spindle with nut, thread M12
PULLER-INTERNAL.SPINDLE-M16	Spindle with nut, thread M16

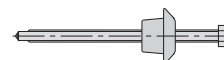

FAG tools for dismantling of rolling bearings

Mechanical ball bearing extractors 56

FAG ball bearing extractors 56

Application

- For extracting complete deep groove ball bearings.
- For tightly fitted outer rings.
- For bearings without radial access.
- Given the fact that the extraction hooks are applied at the outer ring and the threaded spindle is applied at the shaft, the extraction force is forced through the rolling elements, which can render the bearing unusable.

Operation and handling

The claws of the device grasp the raceway edge of the outer ring between the balls and are supported by the inner ring. The bearing is extracted using a threaded spindle. Depending on the bearing size, one of three extractor sizes and one of 13 sets of claws is selected, see table on page 9. The number of arms required and their arrangement in the index plate depends on the number of balls in the bearing. Complete extractor sets consist of one extractor and three or five sets of claws as well as a wrench with a T-shaped handle in the box, see table below.



Product range - ball bearing extractors 56					
Ordering designation Ball bearing extractor set	Depth mm	With claws no.	Wrench with T-shaped handle	Spindle thread	Mass ≈ kg
PULLER56-020-SET	65	01, 02, 03	A/F14	M10	2,1
PULLER56-120-SET	90	1, 2, 3, 4, 5	A/F22	M20×2	3,45
PULLER56-220-SET	150	7, 11, 16, 17, 23	A/F22	M20×2	4,15

FAG tools for dismounting of rolling bearings

Mechanical ball bearing extractors 56

Allocation of extractor sets and claws to standard rolling bearings								
Extractor set	Bearing	Claw no.	Bearing	Claw no.	Bearing	Claw no.	Bearing	Claw no.
PULLER56-020-SET	6004	01	6200	02	6300	01		
	6005	02	6201	02	6301	03		
	6006	01	6202	01	6302	03		
			6203	03				
			6204	03				
			6205	03				
PULLER56-120-SET	6007	1	6206	2	6303	2	6403	4
	6008	1	6207	3	6304	2	6404	5
	6009	1	6208	3	6305	3	6405	5
	6010	1	6209	4	6306	4		
	6011	2	6210	4	6307	4		
	6012	2	6211	4	6308	5		
	6013	2	6212	5				
	6014	3						
	6015	3						
	6016	4						
	6017	4						
	6018	5						
	6019	5						
	6020	5						
PULLER56-220-SET	6021	16	6213	16	6309	16	6406	16
			6214	16	6310	16	6408	7
			6215	16	6311	11	6409	17
			6216	16	6312	17	6410	17
			6217	7	6313	17	6412	23
			6218	17	6314	17		
			6219	17	6315	23		
					6316	23		
					6317	23		
					6318	23		
					6319	23		

FAG tools for dismantling of rolling bearings

Mechanical special bearing extractors 64 for small bearings

FAG special bearing extractors 64

Application

- For radial bearings (deep groove ball bearings and self-aligning ball bearings as well as cylindrical roller, tapered roller and spherical roller bearings). Since the number of rolling elements is not standardised, different grippers may be required for the same bearing sizes from different manufacturers. The bearing manufacturer must be specified when ordering.
- For tight fit of inner ring or outer ring.
- For cases in which the inner ring is adjacent to a shaft shoulder without extraction slots, and also where the bearing to be extracted from the shaft is still inside a housing.
- Extraction without damage is possible with proper handling.
- Max. shaft diameter 75 mm.

Operation and handling

The special extractor consists of a basic unit and a gripper, which is screwed onto the upper section of the basic unit. The gripper is closed using the left hand thread of the union nut and clamped against the inner ring with a conical clamping ring. A threaded spindle generates the extraction force.

The finger-shaped extensions of the gripper engage between the rolling elements on the raceway edge of the inner ring, behind the rollers or behind the chamfer of the bearing ring, wedging it loose. The extraction principle must be observed when selecting the suitable gripper for the respective bearing, see page 25.

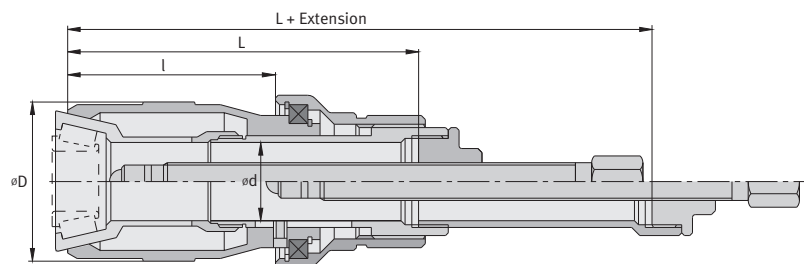

Product range - special bearing extractors 64

Ordering designation Basic unit for special extractor	Dimensions				Spindle thread	Mass ≈ kg
	d mm	D	l	L		
PULLER64-400	30,5	60	78	135	M14×1,5	1,25
PULLER64-500	46	75	80	150	M20×2	2,5
PULLER64-600	66	100	92	170	M22×2	3,8
PULLER64-700	77	126	120	205	M30×2	7,8

The basic unit is selected such that the dimension d is greater than the bearing bore, for example PULLER64-700 (d = 77 mm) for rolling bearing 6015 with 75 mm bore.

FAG tools for dismounting of rolling bearings

Mechanical special bearing extractors 64 for small bearings

Grippers for special bearing extractors 64

The gripping profile of the grippers must be matched to the geometry of the bearing to be extracted. The extraction principle depends on the bearing design and the mounting position. Two grippers are required for tapered roller bearings in X and O arrangements.

Extraction principle A:

For deep groove ball bearings, four point contact bearings, self-aligning ball bearings

The bearing is grasped at the inner ring. Bearings that are located deep in a housing can also be grasped if the outside diameter of the bearing is greater than that of the basic unit.

Ordering designation for grippers:

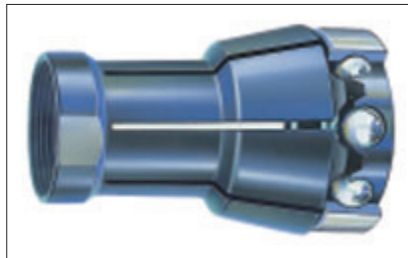

PULLER64.COLLET-A + bearing
(e.g.: **PULLER64.COLLET-A-6000**)

Selection of basic unit and gripper

The basic unit is always selected such that the dimension d is greater than the bearing bore.

Ordering examples for special bearing extractors plus gripper:

- a) For deep groove ball bearings 6000 according to principle A:
Basic device **PULLER64-400** + gripper **PULLER64.COLLET-A-6000**

Extraction principle B:

For tapered roller bearings (fitted in X or O arrangement)

The gripper reaches over the rollers, irrespective of their number. With certain bearing dimensions, bearings that are located deep can also be extracted.

Ordering designation for grippers:

PULLER64.COLLET-B + bearing
(e.g.: **PULLER64.COLLET-B-30203-A**)

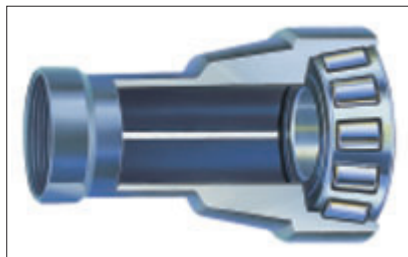

- b) For tapered roller bearing pair 30203-A in X arrangement:
Basic device **PULLER64-400** + gripper **PULLER64.COLLET-B-30203A**
gripper **PULLER64.COLLET-C-30203A**

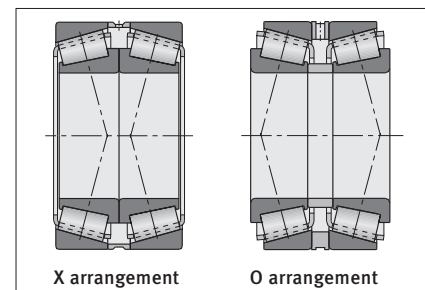

The same grippers are used in reverse for an O arrangement of the tapered roller bearings.

Extraction principle C:

For tapered roller bearings (fitted in X or O arrangement)

The gripper engages behind the large rib of the inner ring.

Ordering designation for grippers:

PULLER64.COLLET-C + bearing
(e.g.: **PULLER64.COLLET-C-30203-A**)

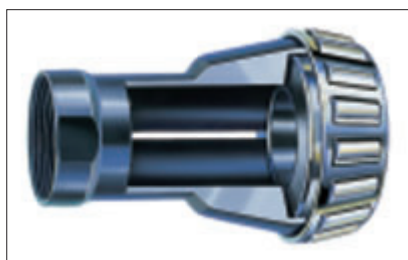

Extraction principle D:

For inner ring of cylindrical roller and four point contact bearings, outer ring of deep groove ball and spherical roller bearings, wedged loose via the bearing ring chamfer

Ordering designation for grippers:

PULLER64.COLLET-D + bearing
(e.g.: **PULLER64.COLLET-D-NU315**)

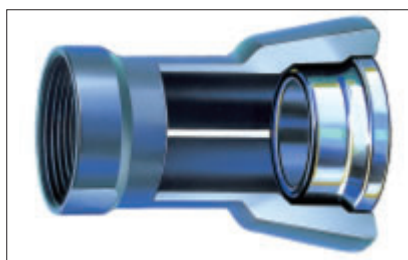

- c) For cylindrical roller bearings NU315 according to principle D:
Basic device **PULLER64-700** + gripper **PULLER64.COLLET-D-NU315**

FAG tools for dismantling of rolling bearings

Mechanical extraction device 49 for small bearings

FAG extraction device 49

Application

- For all rolling bearing types.
For extracting complete rolling bearings or tightly fitted inner rings.
The extractor and the separating device are available in various sizes with openings of up to 210 mm.
- Principally for cases in which the inner ring is adjacent to a shoulder on the shaft without extraction slots. Good radial access to the bearing location is required.
- Extraction of inner rings and complete rolling bearings without damage is possible with proper handling.

Operation and handling

The two wedge-shaped halves of the separating device are inserted between the shaft shoulder and inner ring by alternately tightening the nuts. The separating device is bolted onto the extractor using two tie rods, which are fastened on the cross arm of the extraction device. The bearing or the inner ring are removed by



screwing in the spindle. A tie rod extension is available for parts

that are seated very deeply on a shaft.

Product range - extraction device 49 and separating device

Ordering designation	Span	Depth	Spindle thread	Mass
Extraction device with separating device	mm	mm	mm	kg
PULLER49-100-060	60	150	M14×1,5	1,54
PULLER49-100-075	75	150	M14×1,5	1,67
PULLER49-200-115	115	200	M20×2	5,1
PULLER49-300-150	150	300	M20×2	10,2
PULLER49-400-210	210	300	M30×2	18,8

FAG tools for dismounting of rolling bearings

Hydraulic standard extractors with integral hand pump

Hydraulic FAG standard extractors with integral hand pump

Hydraulic FAG standard extractors with integral hand pump are available for extraction forces of 40, 60 and 80 kN. They allow rolling bearings, gears, bushes and other components to be dismantled effortlessly. They are easy to handle and safe. The compact, light units are housed with a safety grid in a rigid case. PULLER-HYD40 is supplied with a normal arm length. PULLER-HYD60 and PULLER-HYD80 are also available with extended arms (suffix XL).

In addition to the complete devices, we also supply the arms as replacement parts and accessories.

Ordering example for normal length arms as

accessories for PULLER-HYD60-XL / replacement part for PULLER-HYD60:

PULLER-HYD60.JAW

Ordering example for extended arms as

accessories for PULLER-HYD80 / replacement part for PULLER-HYD80-XL:

PULLER-HYD80.JAW-LONG

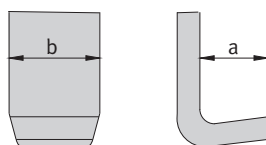

Product range - standard extractors SPIDER with integral hand pump

Ordering designation	Extraction force kN	Span mm	Depth mm	Stroke mm	Dimensions		Mass ≈ kg
					a mm	b	
PULLER-HYD40	40	150	152	55	11	22	4,5
PULLER-HYD60	60	200	152	82	11	22	4,9
PULLER-HYD60-XL	60	200	190	82	11	22	5,2
PULLER-HYD80	80	250	190	75	11	25	6,6
PULLER-HYD80-XL	80	250	229	75	14	25	7

FAG tools for dismantling of rolling bearings

Extra strong hydraulic extractors with integral hand pump

Extra strong hydraulic FAG extractors with integral hand pump

Extra strong hydraulic FAG extractors with integral hand pump are available for high extraction forces of up to 300 kN. They allow rolling bearings, gears, bushes and other components to be dismantled effortlessly. They are easy to handle and safe. The compact units are housed in a rigid metal case. Extractors SPIDER 100 to 300 are also available with extended arms (suffix XL).



Ordering example for normal length arms as accessories for PULLER-HYD100-XL / replacement part for PULLER-HYD100:
PULLER-HYD100.JAW

Ordering example for extended arms as accessories for PULLER-HYD200 / replacement part for PULLER-HYD200-XL:
PULLER-HYD200.JAW-LONG

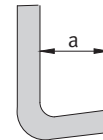
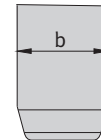

Product range - extra strong extractors SPIDER with integral hand pump

Ordering designation	Extraction force kN	Span mm	Depth mm	Stroke mm	Dimensions		Mass ≈ kg
					a mm	b	
PULLER-HYD100	100	280	182	75	11	22	5,6
PULLER-HYD100-XL	100	280	220	75	11	25	6,5
PULLER-HYD120	120	305	220	75	11	25	7,6
PULLER-HYD120-XL	120	305	259	75	14	29	8,5
PULLER-HYD200	200	356	259	80	14	29	10
PULLER-HYD200-XL	200	356	300	80	30	33	11,5
PULLER-HYD250	250	406	300	100	30	33	20
PULLER-HYD250-XL	250	406	375	100	27	38	22
PULLER-HYD300	300	540	375	100	27	38	25
PULLER-HYD300-XL	300	800	405	100	30	28	45

FAG tools for dismantling of rolling bearings

Extra strong hydraulic extractors with separate hand pump

Extra strong hydraulic FAG extractors with separate hand pump

For extra strong hydraulic FAG extractors for maximum extraction forces of 175 and 400 kN, the oil pressure is applied by a separate hand pump. They allow rolling bearings, gears, bushes and other components to be dismantled effortlessly, even in restricted spaces. The extractors are easy and safe to use. They are housed with the pumps in a rigid metal case. The two hydraulic extractors are available with a normal arm length and with extended arms on request (suffix XL).

Ordering example for normal length arms as accessories for PULLER-HYD175-XL / replacement part for PULLER-HYD175:

PULLER-HYD175.JAW

Ordering example for extended arms as accessories for PULLER-HYD400-XL / replacement part for PULLER-HYD400XL:

PULLER-HYD400.JAW-LONG

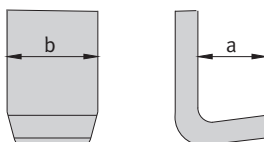

Product range - extra strong extractors SPIDER with separate hand pump

Ordering designation	Extraction force kN	Span	Depth	Stroke	Dimensions		Mass ≈ kg
		mm	mm	mm	a mm	b	
PULLER-HYD175	175	356	229	82	14	29	15,6
PULLER-HYD175-XL	175	356	300	82	30	33	17
PULLER-HYD400	400	800	405	100	30	28	45
PULLER-HYD400-XL	400	1200	635	100	30	28	49

FAG tools for dismantling of rolling bearings

Three-section extraction plates for extractors

Three-section FAG extraction plates

Application

- For extraction of complete bearings or tightly fitted inner rings.
- Principally for cases in which the inner ring is adjacent to a shoulder on the shaft without extraction slots. Good radial access to the bearing location is required.
- Extraction of inner rings and complete rolling bearings without damage is possible with proper handling.

Function

The three extraction plates are pushed, by means of alternately screwing in the nuts, between the shaft shoulder and inner ring. The separating device is screwed onto the extraction plates using three tie rods.

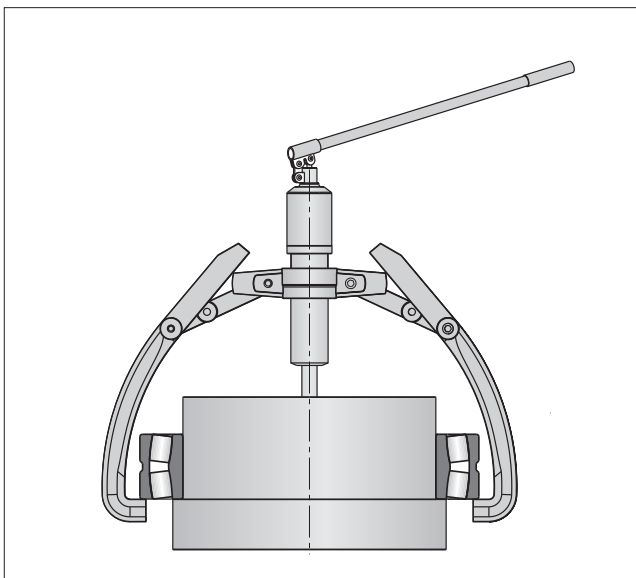
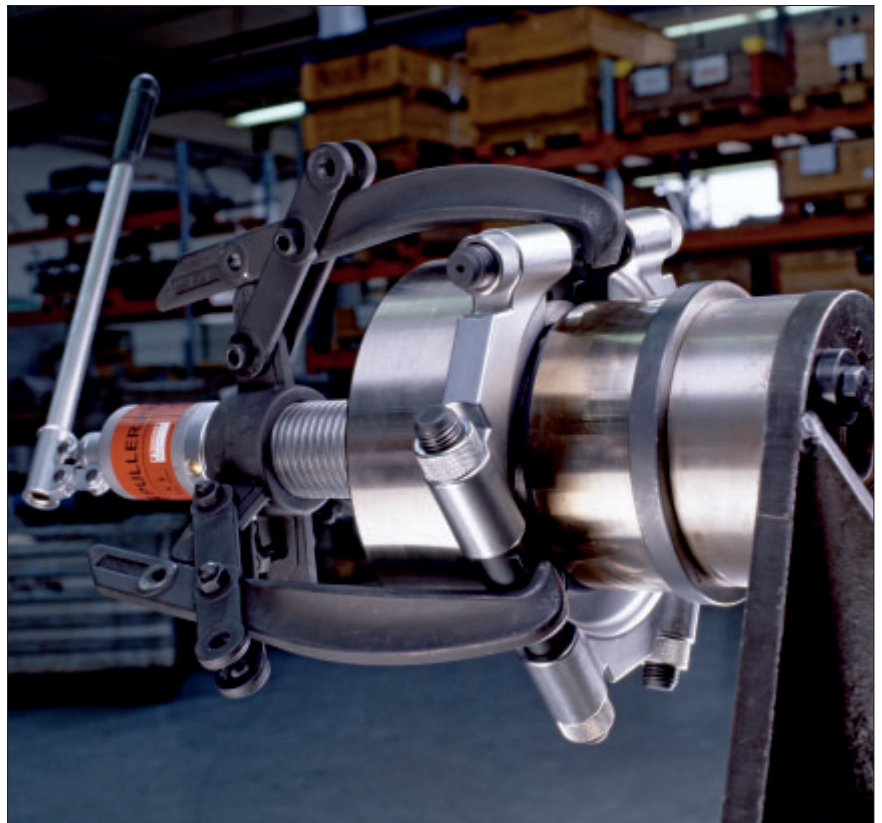

If the extraction forces are directed through the rolling elements, the rolling elements and raceways could be damaged.

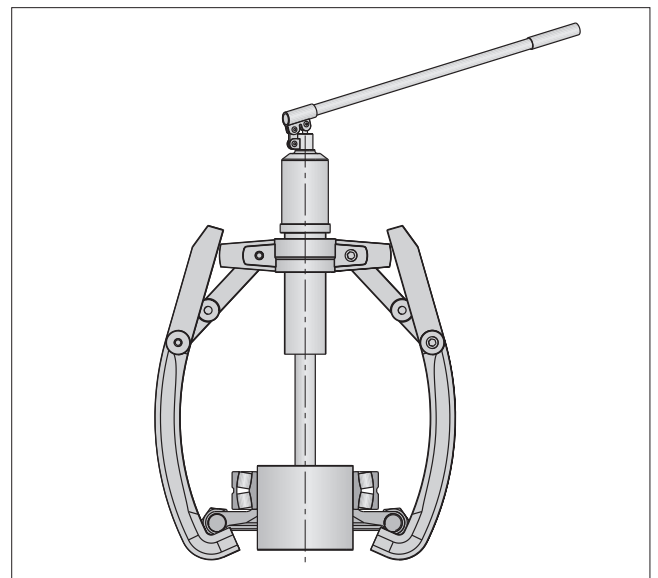

Use of a three-section extraction plate prevents damage because the forces act on the tightly fitted inner rings.

FAG tools for dismounting of rolling bearings

Three-section extraction plates for extractors

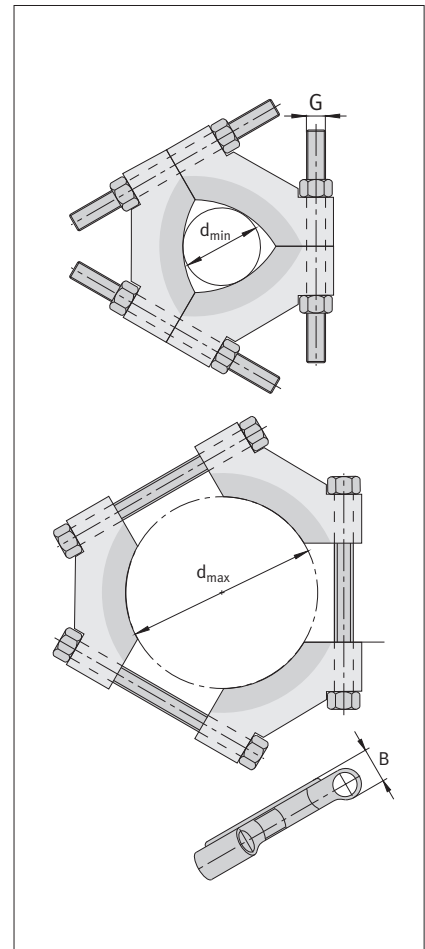

Product range - three-section extraction plates

Ordering designation Extraction plate	Dimensions			Thread G	Mass ≈ kg	Suitable for hydraulic extractor	mechanical extractor
	d _{min}	d _{max}	B				
	mm						
PULLER-TRISECTION-50	12	50	17	M10×1,25	0,5	–	52.085/52.130
PULLER-TRISECTION-100	26	100	28	M16×2	2,6	40/60/80/100	52.230
PULLER-TRISECTION-160	50	160	33,5	M22×2,5	5,8	80/100/120/175/200	52.295
PULLER-TRISECTION-260	90	260	46,5	M32×2,5	18,4	175/200/250/300	52.390
PULLER-TRISECTION-380	140	380	65	M44×2,5	50,3	250/300/400	52.640

Comparison of ordering designations

Comparison of ordering designations	
Ordering designation for Europe	Ordering designation for countries outside Europe
FITTING-TOOL-ALU-10-50	FITTING.TOOL.ALU.SET10-50
FITTING-TOOL-ALU.HAMMER	FITTING.TOOL.ALU.HAMMER
FITTING-TOOL-ALU.RING../..	FITTING.TOOL.ALU.RING../..
FITTING-TOOL-ALU.SLEEVE-A (~B, ~C)	FITTING.TOOL.ALU.SLEEVE-A (~B,~C)
FITTING-TOOL-STEEL-10-50	FITTING.TOOL.STEEL.SET10-50
FITTING-TOOL-STEEL.SLEEVE-A (~B, ~C, ~D, ~E)	FITTING.TOOL.STEEL.SLEEVE-A (~B,~C,~D,~E)
LOCKNUT-DOUBLEHOOK-KM..	LOCKNUT.DOUBLEHOOK.KM...
LOCKNUT-DOUBLEHOOK-KM..-KIT	LOCKNUT.DOUBLEHOOK.KM...KIT
LOCKNUT-DOUBLEHOOK-KM..-...-SET	LOCKNUT.DOUBLEHOOK.KM..-...SET
LOCKNUT-DOUBLEHOOK.LEVER	LOCKNUT.DOUBLEHOOK.LEVER
LOCKNUT-DOUBLEHOOK.WRENCH35 (~100)	LOCKNUT.DOUBLEHOOK.WRENCH35NM (~100NM)
LOCKNUT-FACEPIN-LNP...	LOCKNUT.FACE-PIN.LNP...
LOCKNUT-FLEXIHOOK-KM...	LOCKNUT.FLEXI-HOOK.KM...
LOCKNUT-FLEXIPIN-AM...	LOCKNUT.FLEXI-PIN.AM...
LOCKNUT-HOOK-KM...	LOCKNUT.HOOK.KM...
LOCKNUT-SOCKET-KM...	LOCKNUT.SOCKET.KM...
PULLER44-080 (~150)	ABZIEHER44.080 (~150)
PULLER47-100 (~200)	ABZIEHER47.100 (~200)
PULLER49-100-060 (~200-115)	ABZIEHER49.100.060 (~200.115)
PULLER52-085 (~130, ~230, ~295, ~390, ~640)	ABZIEHER52.085 (~130, ~230, ~295, ~390, ~640)
PULLER54-100 (~200, ~300, ~400, ~500, ~600)	ABZIEHER54.100 (~200, ~300, ~400, ~500, ~600)
PULLER54-SET	ABZIEHER54.SET
PULLER56-020-SET (~120-SET, ~220-SET)	ABZIEHER56.020.SET (~120.SET, ~220.SET)
PULLER62-SET	ABZIEHER62.SET
PULLER62-100-... (~200-...)	ABZIEHER62.100...., (~200....)
PULLER64-400 (~500, ~600, ~700)	ABZIEHER64.400 (~500, ~600, ~700)
PULLER64.COLLET-A-... (~B-..., ~C-..., ~D-...)	ABZIEHER64A... (~B..., ~C..., ~D...)
PULLER-HYD40 (~60, ~80, ~100, ~120)	PULLER.HYD40 (~60, ~80, ~100, ~120)
PULLER-HYD200 (~250, ~300, ~175, ~400)	PULLER.HYD200 (~250, ~300, ~175, ~400)
PULLER-HYD60.JAW	PULLER.HYD60.JAW
PULLER-HYD80.JAW-LONG	PULLER.HYD80.LONGJAW
PULLER-HYD80-XL	PULLER.HYD80XL
PULLER-INTERNAL10/100-SET	PULLER.INTERNAL.SET10-100
PULLER-INTERNAL.ARM-A1-KIT (~A2-KIT)	PULLER.INTERNAL.3ARM-A1 (~A2)
PULLER-INTERNAL.SPINDLE-M12 (~M16)	PULLER.INTERNAL.SPINDLE-M12 (~M16)
PULLER-TRISECTION-50 (~100, ~160, ~260, ~380)	PULLER.TRISECTION50 (~100, ~160, ~260, ~380)

**Schaeffler Technologies
GmbH & Co. KG**

Postfach 1260
97419 Schweinfurt
Germany

Georg-Schäfer-Straße 30
97421 Schweinfurt
Germany

Phone +49 2407 9149-66
Fax +49 2407 9149-59

E-Mail info@schaeffler-iam.com
www.schaeffler-iam.com

Every care has been taken to ensure the correctness of the information contained in this publication but no liability can be accepted for any errors or omissions. We reserve the right to make technical changes.

© Schaeffler Technologies GmbH & Co. KG

Issued: 2011, May

This publication or parts thereof may not be reproduced without our permission.

TPI WL 80-56/2 EA